

PROGRESSIVE CAVITY PUMPS

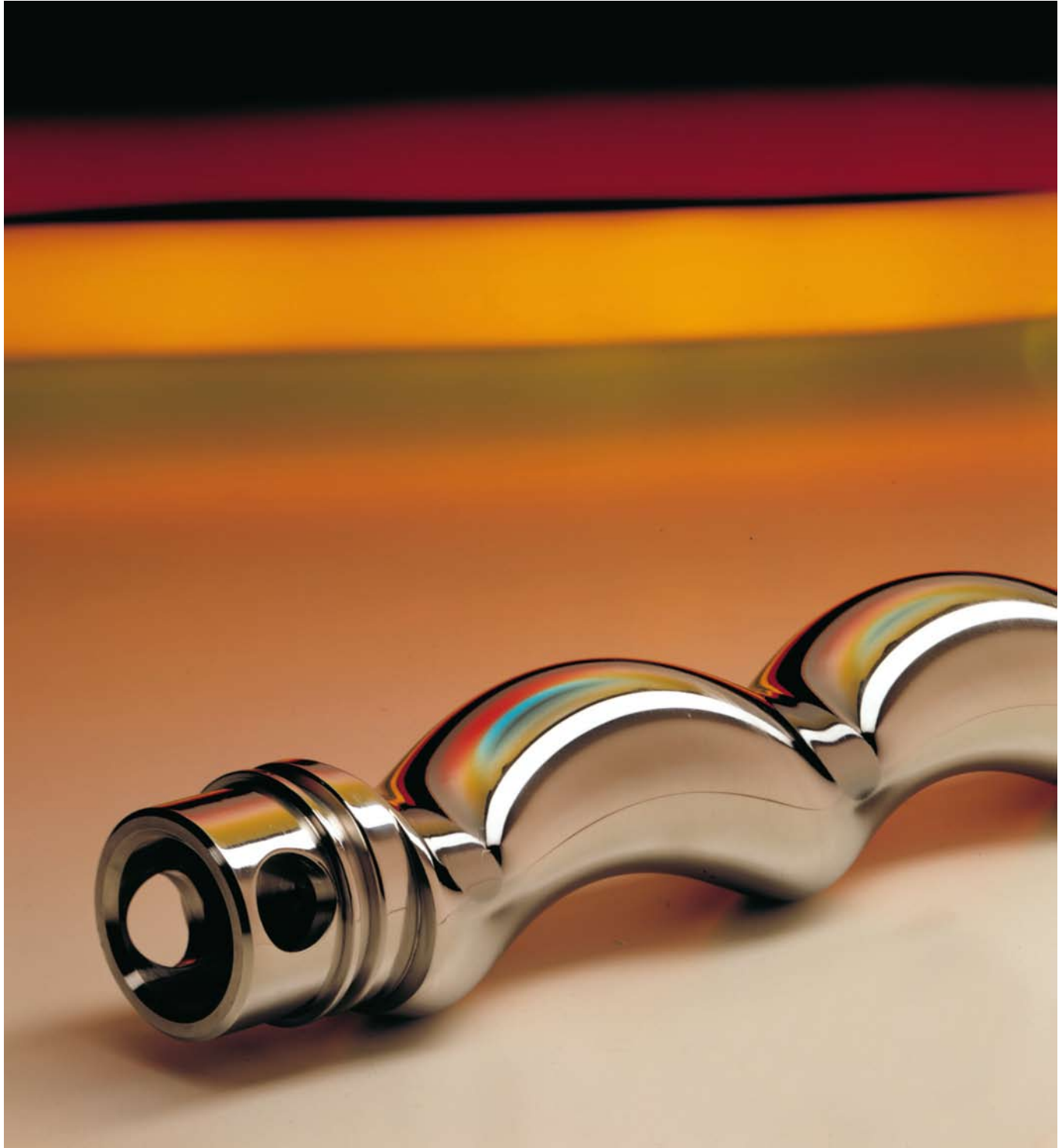

PROGRESSIVE
CAVITY
PUMPS



C.S.F. INOX SPA

PREFACE AND WARNING

This publication does not constitute a contract proposal or an offer to the public or product advertisement.

This publication is reserved to the internal operators of C.S.F. INOX.

Any kind of product sale and marketing can occur only according to the general terms of contract and special conditions listed by C.S.F. INOX as per contract forms.

All the instructions, data and representations (in whatever way executed) listed in this publication are indicative and do not binding.

C.S.F. does not stand surety or undertake any obligation for the utilisation of this document and for the information contained. In particular, it does not guarantee against omissions or errors of the data and drawings here indicated.

Notice that the technical specifications, information and representations in this document are merely indicative and approximate.

C.S.F. INOX reserves the right at any moment and without notice to modify the data, drawings and information indicated in this document.

C.S.F. INOX recommends anyone to verify with the C.S.F. INOX operators contractual conditions and the product characteristics as per the official documents attached to all products in the C.S.F. INOX range.

All the general and non-binding technical specifications and representations may not correspond to the real conditions of the products and to their operating modes for each different application.

C.S.F. INOX guarantees its own products according to the general guarantee conditions in compliance with the required modes of utilisations as per separate documents, regardless of what is indicated in this document, if the assembly and operating methods of the products are observed.

Only the instructions indicated in the contract documents, if duly undersigned by authorised C.S.F. INOX personnel, are binding for C.S.F. INOX.

We remind our technical and business collaborators to show the customer our range of products indicating the technical specifications of each type, with the conditions of utilisation and the actual utilisation methods.

Please consider this warning carefully because C.S.F. INOX shall not be liable for any utilisation of this document, of the data and representations here indicated.

PROGRESSIVE CAVITY PUMPS

The progressive cavity pump is a positive displacement, self-priming pump with one single rotating shaft. The steel rotor and rubber stator are the main pumping components.

The rotor is a circular section single or double-threaded screw with short or long pitch. The rubber stator is vulcanized inside a steel pipe. Its hollow core is screw shaped like the rotor but with pitch double the size of the rotor.

The rotor turns inside the stator and is forced to accomplish a hypocycloidal movement during which the recesses between the rotor and the stator accomplish an helicoidal movement, conveying the fluid from the inlet towards the delivery section.

STANDARD GEOMETRY CHARACTERISTICS

- uniform and delicate flow
- wide section allowing solid suspensions to flow freely
- low flowing rate and excellent NPSH
- compact size with respect to the maximum allowable pressure and to the number of stages
- suitable for high and very viscosity
- suitable for compact and pasty products

LONG PITCH GEOMETRY CHARACTERISTICS

- high volumetric efficiency
- extremely delicate flow without pulses
- nearly double delivery at the same operating speed compared to the standard design
- reduced wear of the parts thanks to the low contact speed between rotor and stator
- suitable for medium-low viscosity and abrasive products
- compact size with relation to the maximum delivery
- minimum axial thrusts on transmission and bearings

2/3 THREAD GEOMETRY CHARACTERISTICS

- high volumetric efficiency
- good dosing precision
- delivery approximately equal to 1,5 times the standard geometry at the same operating speed
- suitable for medium-low viscosity products and without solid materials in suspension
- extremely compact size with relation to the maximum delivery



GENERAL CHARACTERISTICS

DELIVERY

Thanks to the volumetric operating principle, the delivery of the progressive cavity pump is directly proportional to the number of revolutions.

PRESSURE

The differential pressure depends on the number of stages and on the characteristics of the pumped fluid; in case of non abrasive fluids, the maximum allowable pressure per stage is equal to 6 bar.

TEMPERATURE

The maximum working temperature of the fluid depends on the type of stator. It also depends on the kind of fluid and the operational conditions of the pump.

IN-TAKE

The screw pump is self-priming even at low running speeds and with fluids such as water at a temperature of 20° C., specific weight = 1 Kg/dm³ and viscosity 1°E it is capable of in-taking a 7-meter column.

DELIVERY

The pump works according to the principle of the volumetric pumps, namely with positive displacement, pumping a constant amount of fluid, smoothly and without sudden variations in flow rate.

FLUIDS THAT CAN BE PUMPED

This type of pump (compatibly with the chemical and mechanical resistance of the elastomer of the stator) is capable of pumping almost all types of non-Newton fluids up to a viscosity of 150/200.000 cP and with pumps of the MC series up to a viscosity of 800.000 cP. Fluids with solid suspended substances can be pumped (provided that they are not abrasive) without compromising the perfect efficiency of the pump.

STARTING AND ADJUSTMENTS

To safeguard the pump stator fill the pump with the fluid to be pumped and ensure that the stop valves on the inlet and outlet are completely open.

To adjust the fluid flow rate adjust the pump speed if it is coupled with a continuous variable speed motor or fit an adjustable by-pass valve between the outlet and inlet.

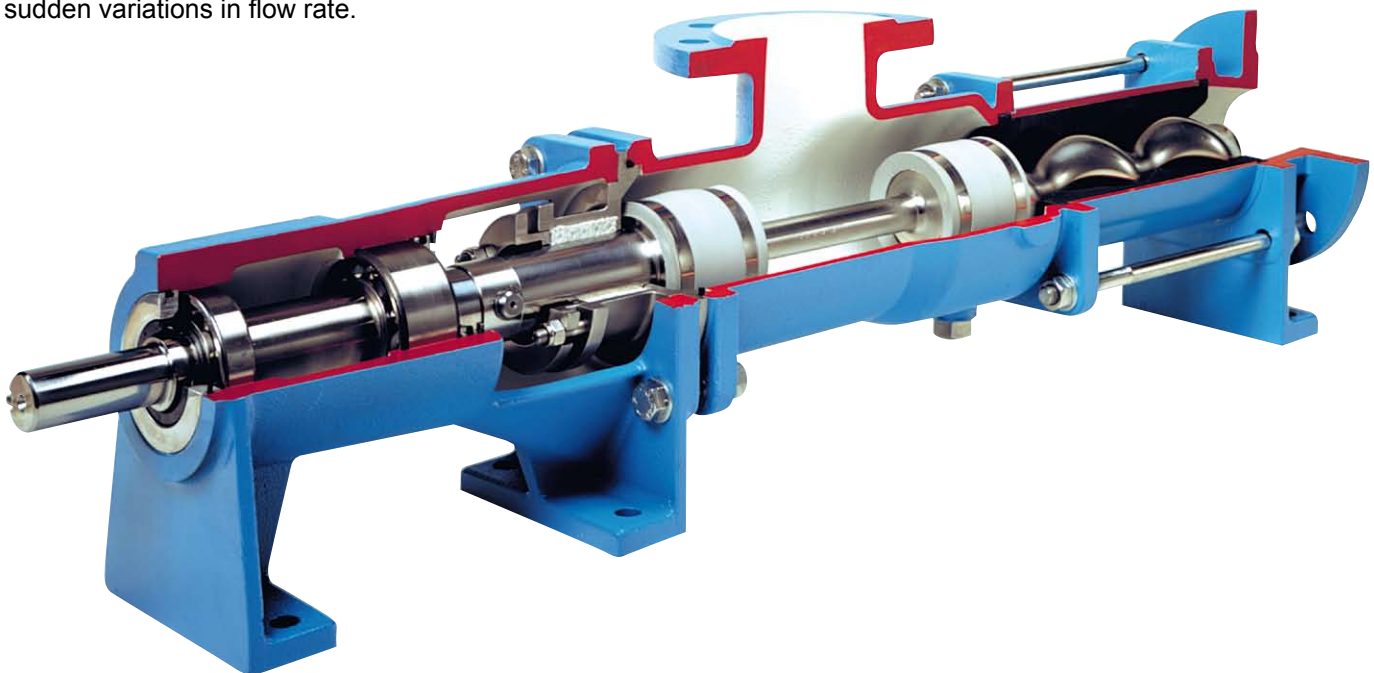

WARNINGS

- 1) Never run the pump without fluid. This could damage the stator's elastomer.
- 2) Never adjust the flow rate by choking the delivery valves, considering that the pump is the positive displacement type, the stress on the rotor axis would be increased with consequent damage to the drives and motor, if these are not protected by overload micro-switches.

DATA REQUIRED TO CHOOSE THE RIGHT PUMP

- 1) Type of installation and use of the system for which it is to be used.
- 2) Flow rate in litres/min or m³/h.
- 3) Total delivery pressure (bar).
- 4) Available NPSH, or in-taking conditions (pressure or vacuum, head, piping, valves etc.).
- 5) Chemical-Physical nature of the fluid to be pumped: chemical composition, pH, viscosity, density and temperature.
- 6) Presence of suspended solid particles (max. dimension) and abrasiveness.
- 7) Power supply voltage and frequency of the motor.
- 8) Type of Motor-Pump coupling (direct with gear motor with variable speed motor – bare shaft pump).

MAIN APPLICATIONS

FOOD PROCESSING INDUSTRIES

- Various concentrates
- Whole tomatoes
- Mushed tomatoes
- Marmalades - Jams
- Various fruits
- Fruit salad
- Vegetables
- Various creams
- Dairy cream
- Vegetable extracts
- Meat extracts
- Various juices
- Melted cheese
- Honey - Eggs - Icing - Lard
- Cake dough
- Fish paste
- Milk and by-products
- Homogenised products
- Various sauces
- Vegetable fats
- Oils and sauces
- Treacle
- Gelatine solutions
- Chocolate, sweet fruit pickles, pectin
Mustard
- Pasteurisor feeding
- Press feeding

TILE, BUILDING AND RELATED INDUSTRIES

- Slurry
- Casting paste
- Clay products
- Various mud
- Various malts
- Cement milk
- Glass sludge
- Various drainage water
- Mixes - Asbestos - Cement

BEVERAGE INDUSTRIES

- Distilled products
- Wines and spirits
- Bear and malt
- Filter feeding
- Essences - Aromas
- Mineral waters
- Syrups - Yeasts
- Filling machine feeding
- Milk of lime

COSMETIC AND PHARMACEUTICAL INDUSTRY

- Various creams
- Toothpaste
- Soaps - Shampoo - Detergents
- Bubble bath
- Vitamin solutions
- Emulsions and dispersions
- Hand-cleaning pastes

CHEMICAL – PRINTING – EXTRACTIVE AND TEXTILE INDUSTRIES

- Essences - Resins - Glues
- PVC pastes - Waxes - Sizes - Alum
- Anti-cryptogram solutions
- Paints and varnishes
- Printing inks
- Fertilizers
- Acids
- Lyes
- Dextrins
- Paper pastes
- Starch solutions
- Cellulose
- Petrol - Oils
- Sludges
- Milk of lime
- Aniline water

WATER PURIFYING AND CONDITIONING PLANTS

- Sewage water
- Various mud
- Sea lime
- Cesspool sewage
- Lyes
- Various suspended water or mud processing waste
- Slaughterhouse waste
- Fish processing waste
- Organic waste
- Tannery waste

OENOLOGICAL INDUSTRY

- Musts and concentrates
- Wine
- Grapes without stalks
- Whole grapes
- Crushed grapes with stalk
- Dregs of crushed grapes
- Pressing waste
- Filtration
- Refrigeration
- Bottling

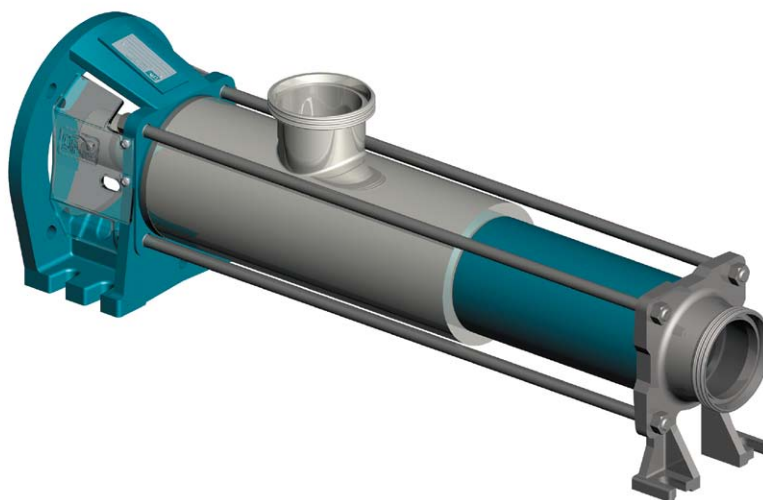

VARIOUS EXECUTIONS

SERIES **MA** FOODSTUFFS EXECUTION

Pumps for foodstuffs with large suction chamber, free from product stagnation zones.

All parts in contact with the product are in polished / glazed stainless steel. The inlet and outlet fittings are threaded according to DIN 11851 standards and on request in the SMS, CLAMP, RJT-BS and IDF, OENOLOGICAL versions. The rubber stator is directly vulcanised in a steel tube.

The special telescopic assembly means that the whole pump can be disassembled without having to remove its drive, thus amazingly facilitating the inspection of all parts for cleaning and maintenance purposes.

The MAE series, with pump directly coupled to the drive, allows to minimise the overall dimensions and costs, yet leaving the pumping part with the same characteristics and disassembly facility as the MAN series.

MAE

exec. CLOSED COUPLED

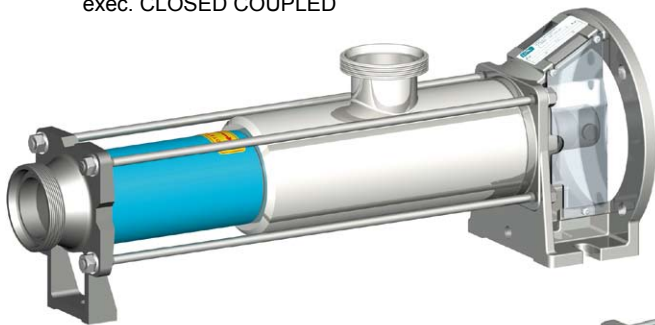

MAN

exec. WITH BASE AND FLEXIBLE JOINT

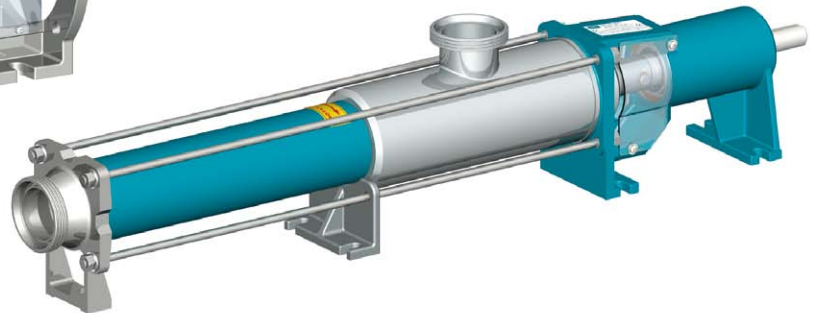

SERIES **MI** INDUSTRIAL EXECUTION

Industrial sturdy pumps suitable for heavy duty requirements. Fully made in stainless steel or cast iron with steel axel shaft. The inlets and outlets are flanged according to UNI 2223 PN16 standard. The rubber stator is directly vulcanised in a steel tube.

The MIE series, with pump directly coupled to the drive, allows to minimise the overall dimensions and costs, yet leaving the pumping part with the same characteristics and disassembly facility as the MIN series.

MIE

exec. CLOSED COUPLED

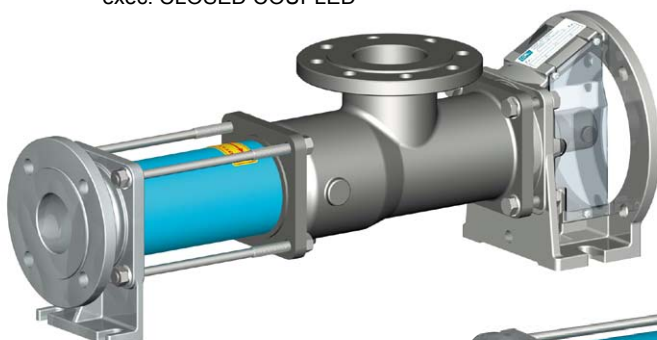

MIN

exec. WITH BASE AND FLEXIBLE JOINT

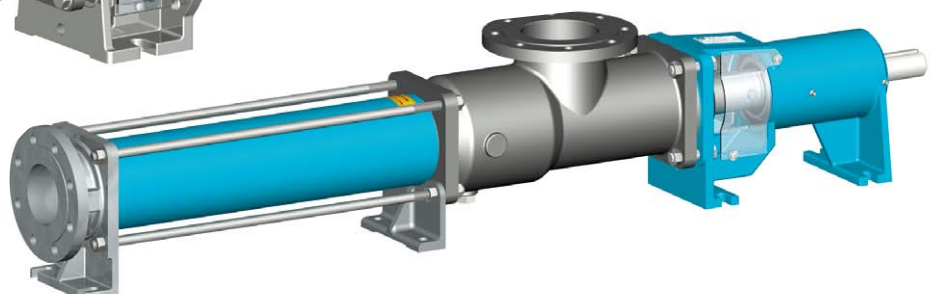

VARIOUS EXECUTIONS

SERIES MC EXECUTION WITH HOPPER AND PRE-FEEDING SCREW

Version with hopper equipped with pre-feeding screw suitable for viscous products that do not flow easily inside the pipes. The top part is equipped with a rectangular flange to which any type of conveyance system can be connected.

The outlet can be with DIN 11851 fitting or with UNI 2223 PN16 flange. It can be manufactured on request in the SMS, CLAMP, RJT-BS, IDF and OENOLOGICAL versions.

The MCE series, with pump directly coupled to the drive, allows to minimise the overall dimensions and costs, yet leaving the pumping part with the same characteristics and disassembly facility as the MCN series.

A lid with fitting means that the pump can be used for the typical applications of the MA series.

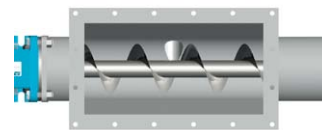

MCE

exec. CLOSED COUPLED

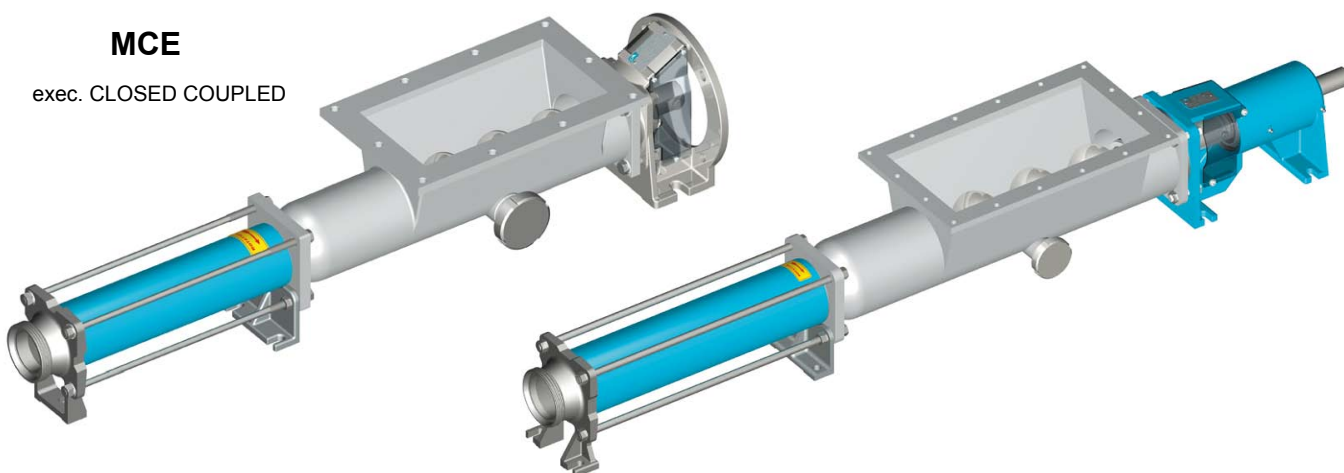

MCN

exec. WITH BASE AND FLEXIBLE JOINT

SERIES MCR EXECUTION WITH HOPPER, PRE-FEEDING SCREW AND VANE CRUSHER

Version with hopper equipped with pre-feeding screw and vane crusher, suitable for dense products in blocks, pieces or that tend to form a bridge on the screw.

The vane crusher driven by an independent speed gear motor, crushes the product to be pumped, breaking down any blocks that have built up and pushes it against the pre-feeding screw.

The outlet may be equipped with DIN 11851 fitting or UNI 2223 PN16 flange. It can be manufactured in the SMS, CLAMP, RJT-BS, IDF and OENOLOGICAL versions.

As for the MC series, it can be in the E or N version and it can be supplied, on request, with a lid.

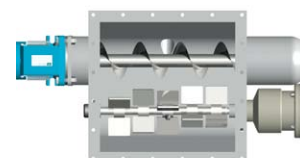

MCRE

exec. CLOSED COUPLED

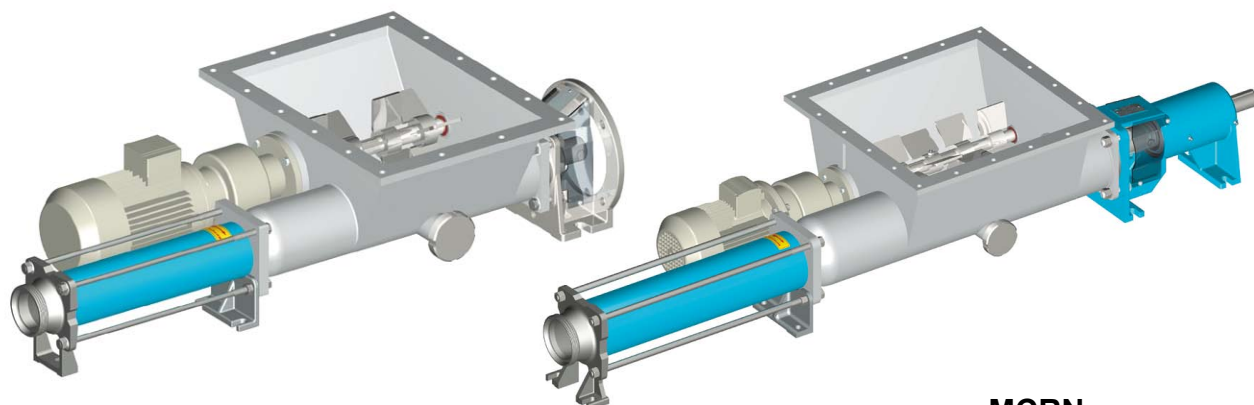

MCRN

exec. WITH BASE AND FLEXIBLE JOINT

VARIOUS EXECUTIONS

- SERIES MC2C** EXECUTION WITH HOPPER AND 2 PRE-FEEDING SCREWS
- MC2CR** EXECUTION WITH HOPPER, 2 PRE-FEEDING SCREWS AND 1 BLADE FEEDER

Version with hopper and double synchronised pre-feeding screw, with vane crusher operated by a reduction unit. The two pre-feeding screws pull the product to feed the pump stator. The vane crusher blades push the product towards the bottom of the hopper thus feeding the two pre-feeding screws and preventing product stagnation. They are ideal for very viscous products that do not flow easily, such as dough, minced products and products in blocks.

The outlet can be equipped with DIN 11851 fitting or UNI 2223 PN16 flange. It can be manufactured in the SMS, CLAMP, RJT-BS and IDF versions.

Suitable for products in blocks for which a crushing is required to feed the pump screw:

The series consists of the following sizes: M65 - M80 - M100 - M125.

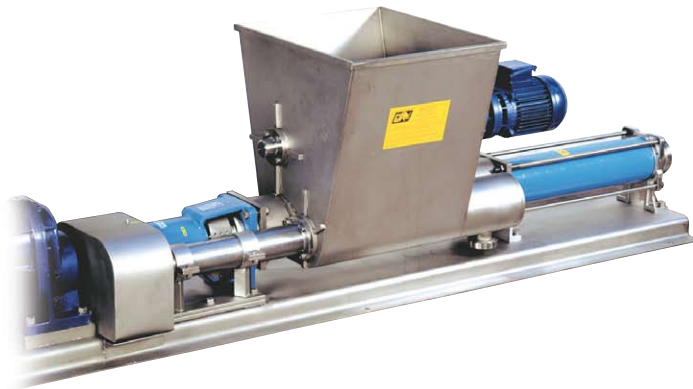

exec. MC2C

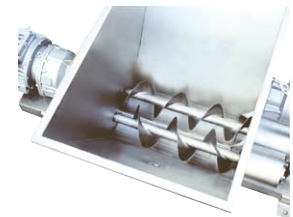

exec. MC2CR

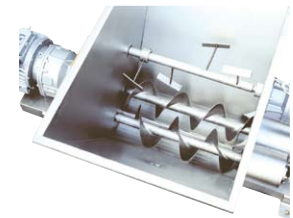

BLADE FEEDERS WITH 2 PRE-FEEDING SCREWS

Version with hopper and double synchronised pre-feeding screw operated by a reduction unit. It can be manufactured as a simple feeder or in combination with a lobe pump.

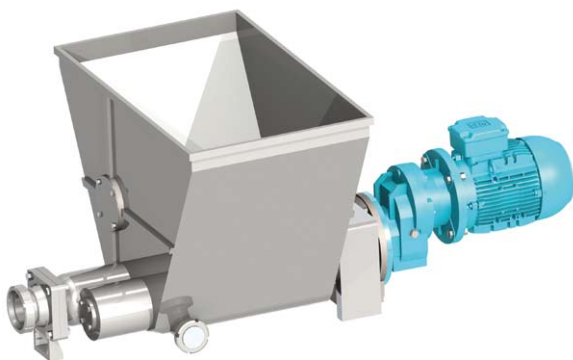

BLADE FEEDER WITH
2 PRE-FEEDING SCREWS

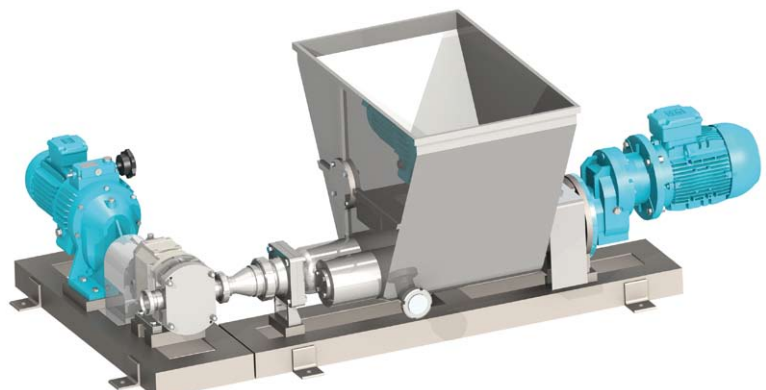

BLADE FEEDER WITH LOBE PUMP

VARIOUS EXECUTIONS

SERIES MAV VERTICAL EXECUTION



Exec. with pneumatic hoist

The MAV series progressive cavity pumps are designed for vertical operation with the inlet immersed in the product. The range consists of the following models, MAV 40, 50, 60L, 65, 70L, 80, 90L manufactured in stainless steel AISI 316.

MAV Series pumps are intended for product transfer and drum or container emptying applications, in which the suction port is plunged directly into the product.

As standard, MAV pumps have a suction to discharge port dimension of 1100 - 1400 mm. On request, this distance can be personalised to suit a customer's requirements.

It can be mounted on a drum-holding hoist, with a choice of either a manual sliding or an alternative pneumatic lift and lower system.

The operating characteristics and construction materials of these pumps enable the MAV series to be used with many different fluids, from low to high viscosity, including many abrasive and corrosive media. An added benefit is the ability to handle fluids containing fibres or solid materials in suspension.

The main components of the MAV series pumps, such as the stator, rotor, joints and mechanical seal are the same as used on the corresponding horizontal version.



Exec. with rotating table for 4 drums

There is a version with suction port in two pieces. This is in order to achieve alternative solutions relating to various uses and the need to perform CIP washing at the end of the cycle.

- A = immersed port with bag protection for fluid products.
- B = immersed port with suction cone for dense products.
- C = port with plate and bag protection for very viscous products.
- D = 90° elbow for CIP washing.

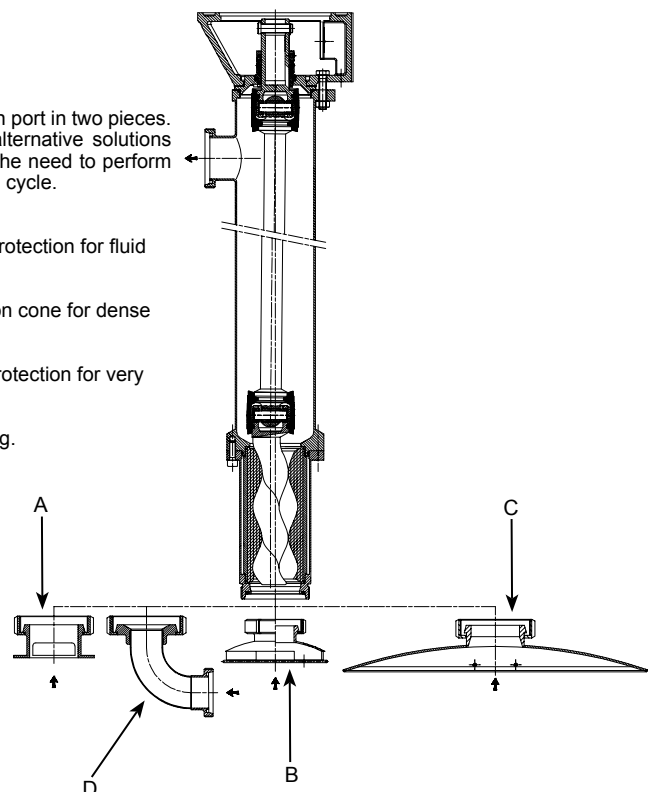

VARIOUS EXECUTIONS

PROGRESSIVE CAVITY PUMP WITH **CRUSHING BLADES**

For crushing your products containing soft or fibrous components (fruit and/or vegetables), CSF Inox has designed the right solution for you.

By using crushing blades mounted on the rotor with a disc having holes of different sizes, the consistency of the mashed product can vary. The great advantage of this device is to avoid using the macerating machines after the pump.

Available sizes:
MC-MCR 80; MC-MCR 100; MC-MCR 125; MC-MCR 150.

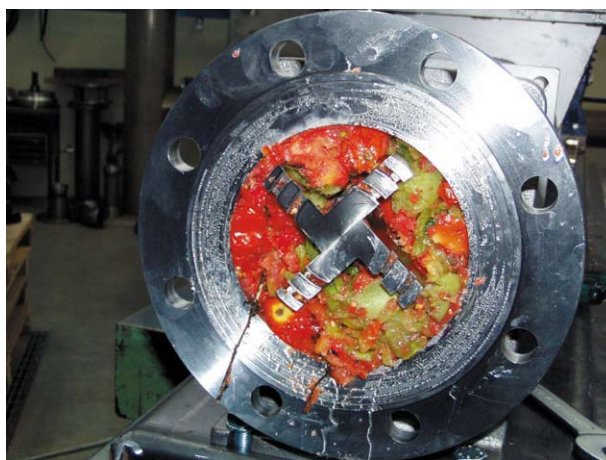

CRUSHING BLADES KIT

When necessary, you can easily equip the pump with the crushing blade kit, after having fixed a bush into the rotor head.

PUMPS AND ACCESSORIES FOR THE WINE INDUSTRY

Pressing - Transfer of pressed grapes, mash, musts and wine

MCPE series



MCR series

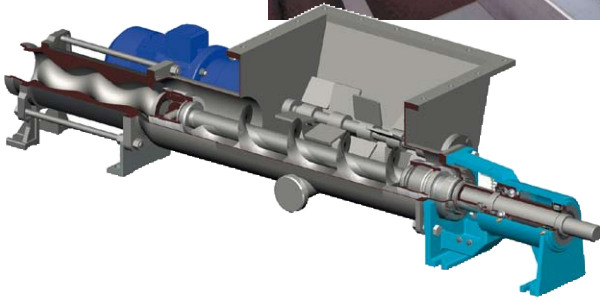

Filling and emptying of barrels

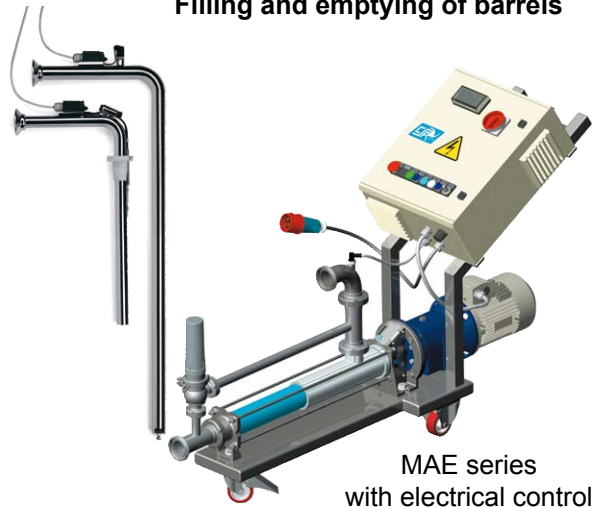

MAE series
with electrical control
panel enclosure
for stainless steel probes

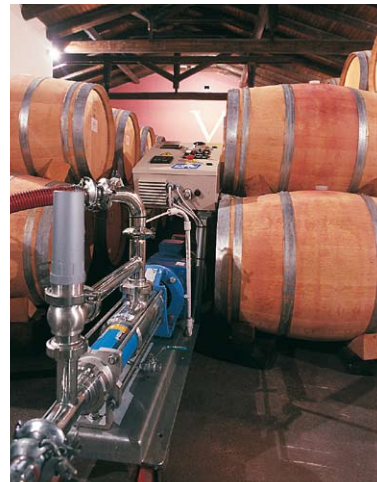

Recirculation - Decanting



MAE series

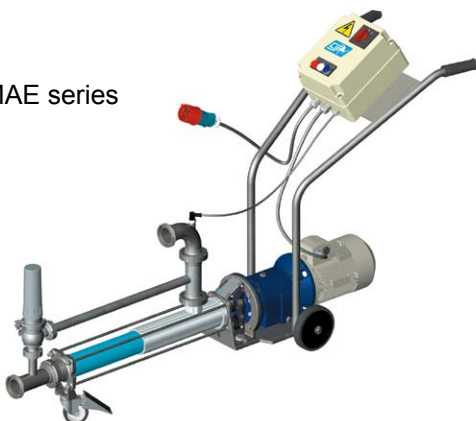

Bottling - Filtration - Refrigeration



MAE series
with electrical control
panel enclosure

PUMP SIZING

DIAGRAM FOR THE CHOICE OF SCREW PUMPS

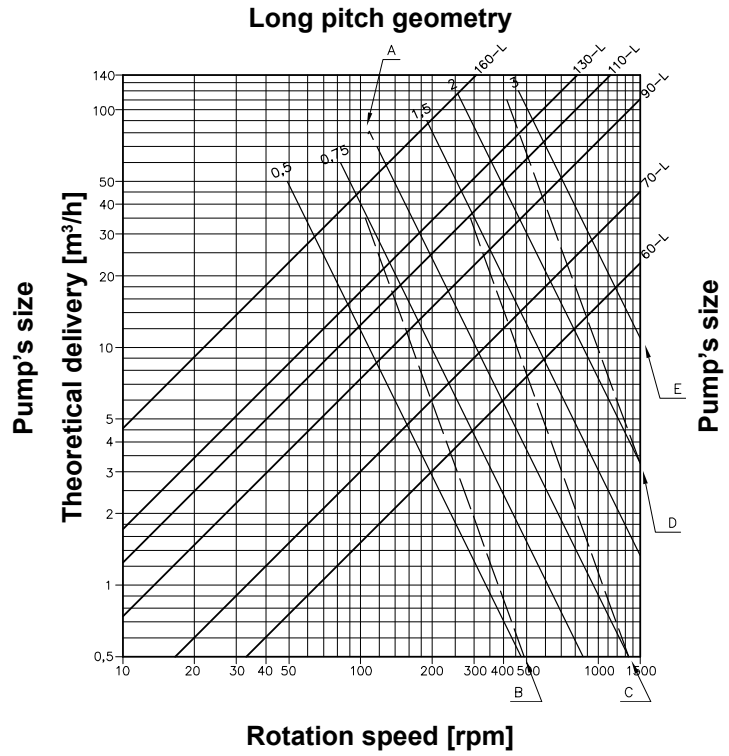
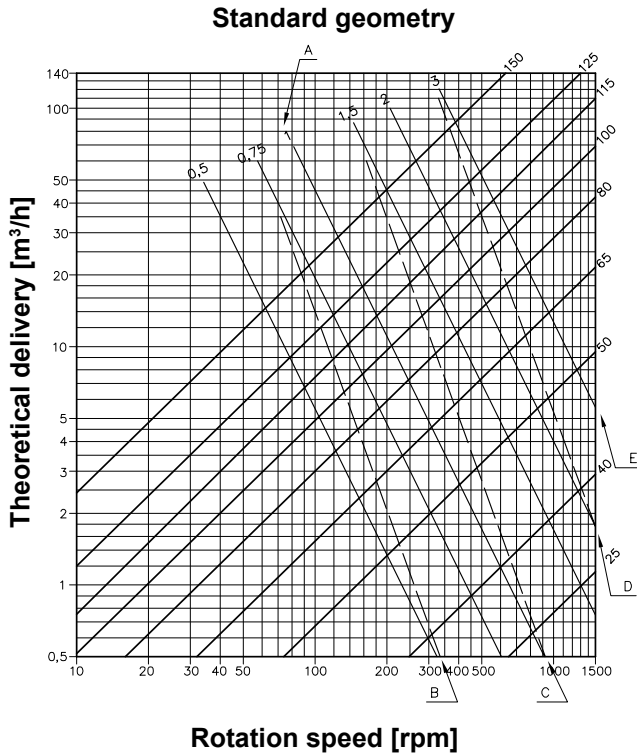

A = Rotor/stator drive speed
in m/sec

B = Very abrasive _____
Very viscous - - - - -

C = Averagely abrasive _____
Averagely viscous - - - - -

D = Not very abrasive _____
Not very viscous - - - - -

E = Not abrasive

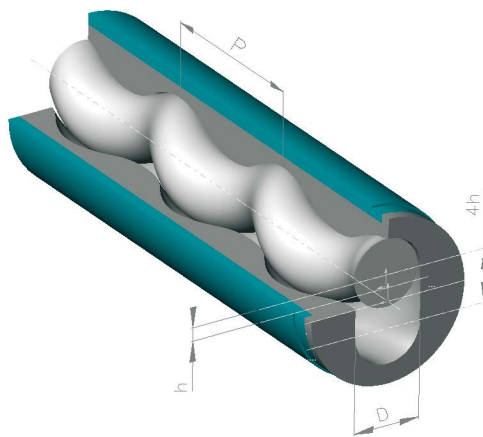

ABSORBED POWER CALCULATION

$$NA = \frac{Q \cdot H \cdot \gamma}{4500 \cdot \eta}$$

Q = Flow rate in l/min.

Na = Absorbed power in Hp.

H = Total head in meters of liquid column

γ = Specific weight of the liquid in kg/dm³.

η = Total efficiency (volumetric efficiency multiplied by mechanical efficiency)

THEORETICAL DELIVERY CALCULATION

The output of the CSF screw volumetric pumps is directly proportional to the rpm:

$$Q = D \cdot 4h \cdot 2P \cdot N$$

Q = Flow rate in l/min.

h = Eccentricity of rotor in dm.

P = Rotor pitch in dm.

2P = Stator pitch

n = rpm.

d = Diameter of rotor in dm.

PERFORMANCES

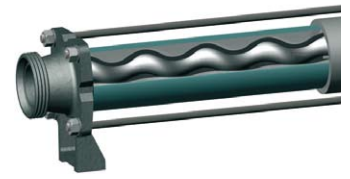
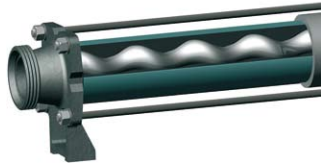
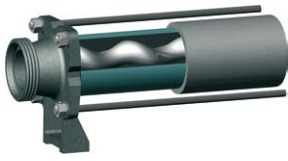

1 stage - max. 6 bar

2 stages - max.12 bar

1 stage "S" - max. 10 bar

2 stages "S" - max. 22 bar

h = Head, bar Q = Flow rate, m³/h Na = Power, HP n = rpm

Values referred to water at 20°C a.s.l.

Size	Stages	Version N	Version E	h	n=200		n=300		n=400		n=500		n=600		n=700		n=800		n=900		n=1000		n=1400	
					Q	Na	Q	Na	Q	Na	Q	Na	Q	Na	Q	Na	Q	Na	Q	Na	Q	Na	Q	Na
25	1	--	MAE	1					0,3	0,23	0,38	0,24	0,45	0,25	0,52	0,26	0,6	0,27	0,68	0,28	0,75	0,3	1,05	0,35
				2					0,3	0,26	0,38	0,27	0,45	0,28	0,52	0,3	0,6	0,31	0,68	0,33	0,75	0,34	1,05	0,39
	4					0,25	0,28	0,33	0,3	0,4	0,32	0,46	0,33	0,54	0,35	0,52	0,37	0,68	0,39	0,96	0,45			
	2	--	MAE	6							0,38	0,35	0,45	0,38	0,52	0,40	0,6	0,43	0,66	0,46	0,75	0,49	1,05	0,58
40	1	MAN MCN	MAE MCE	1					0,6	0,35	0,8	0,35	1	0,35	1,2	0,4	1,4	0,45	1,6	0,5	1,8	0,55	2,6	0,8
				3					0,3	0,35	0,5	0,35	0,7	0,4	0,9	0,45	1,1	0,5	1,3	0,55	1,5	0,6	2,3	0,85
	6									0,2	0,45	0,4	0,5	0,6	0,55	0,8	0,6	1	0,65	1,8	0,9			
	2	MAN MCN	MAE MCE	9							0,3	0,6	0,5	0,7	0,7	0,8	0,9	0,9	1,1	1	1,3	1,1		
50	1	MAN - MIN MCN - MCRN MC2RN	MAE - MIE MCE - MCRE	1	0,9	0,6	1,5	0,6	2	0,6	2,6	0,7	3,2	1	3,8	1,2	4,3	1,2	4,8	1,4	5,4	1,6	7,8	2,1
				3	0,8	0,8	1,3	0,9	1,8	1	2,4	0,9	3	1,2	3,5	1,3	4,1	1,4	4,6	1,6	5,2	1,8		
	6	0,6	0,9	1,1	1,1	1,6	1,1	2,2	1,2	2,8	1,5	3,3	1,6	3,9	1,7	4,4	2	4,9	2,3					
	2	MAN - MIN MCN - MCRN MC2RN	MAE - MIE MCE - MCRE	9	0,2	1,1	0,9	1,2	1,6	1,6	2,1	2	2,8	2,4	3,5	2,7	4,2	2,8	4,9	3,1				
55	4	MAN - MIN MCN - MCRN MC2RN	MAE - MIE MCE - MCRE	8	1	1,5	1,6	1,7	2,2	2	2,8	2,5	3,4	3										
				16	0,7	1,8	1,3	2,3	1,8	2,8	2,4	3,4	3	4,2										
	24	0,4	2,2	0,8	3	1,3	3,6	1,9	4,4	2,4	5,2													
	60	L	MAN - MIN MCN - MCRN MC2RN	MAE - MIE MCE - MCRE	2	2,5	1,2	3,7	1,3	5	1,4	6,2	1,6	7,5	1,8	8,7	2	10	2,2	11,2	2,5	12,5	2,7	
4					2,3	1,5	3,5	1,7	4,7	1,8	5,8	2	7	2,3	8,2	2,6	9,4	2,8	10,6	3,2	11,7	3,5		
6		2	1,7	3,1	1,9	4,2	2,1	5,2	2,4	6,4	2,6	7,4	3	8,5	3,4	9,6	3,8	10,7	4,1					
65		1	MAN - MIN MCN - MCRN MC2RN	MAE - MIE MCE - MCRE MC2CE	1	2,5	1,1	3,8	1,1	5	1,4	6,4	1,5	7,6	1,7	8,7	2	9,7	2,3	11,3	2,6			
	3				2,3	1,2	3,6	1,2	4,5	1,6	5,9	1,9	7,3	2,2	8,4	2,4	9,4	2,5	10,8	3,2				
	6	1,7	1,5	2,8	1,7	4	2,1	5	2,6	6,5	2,8	7,5	3,2	8,5	3,4									
	2	MAN - MIN - MCN MCRN - MC2RN	MAE - MIE MCE - MCRE MC2CE	9	1	2,8	2,6	3,3	4,1	3,7	5,7	4,2	7,3	4,9	8,8	6								
70	L	MAN - MIN MCN - MCRN MC2RN	MAE - MIE MCE - MCRE	2	5,4	2	8	2,3	10,6	2,8	13,1	3,3	15,9	3,9	18	4,5								
				4	5	2,3	7,6	3	10,3	3,7	12,8	4,4	15,5	5,4										
	6	4,6	2,8	7,2	3,7	9,8	4,6	12,1	5,8															
	80	1	MAN - MIN MCN - MCRN MC2RN	MAE - MIE MCE - MCRE MC2CE	1	4,7	2,2	7,5	2,5	10,1	2,9	12,7	3,2	15,5	3,5	18	3,7							
3					4,4	2,5	7	3	9,6	3,3	12,1	3,8	14,8	4,5	17,4	5,2								
6		3,8	2,9	6,4	3,5	8,9	4,3	10,9	5	13,4	6,2													
2		MAN - MIN - MCN MCRN - MC2RN	MAE - MIE MCE - MCRE MC2CE	9	3,2	2,9	5,5	3,5	8	4,5	11	6	14	7,2										
90	L	MAN - MIN MCN - MCRN MC2RN	MAE - MIE MCE - MCRE	14	3,8	7,8	6,8	9,2	9,8	11	12,8	13,2												
				17	2,9	8,2	5,8	9,8	9	11,9														
	20	0,7	9	3,5	11	6,5	14																	
	4	MAN - MIN MCN - MCRN MC2RN	MAE - MIE MCE - MCRE MC2CE	8	5,5	2,5	8,1	3,3	11,5	4,5	14	5,5												
100	1	MAN - MIN MCN - MCRN MC2RN	MAE - MIE MCE - MCRE MC2CE	16	4	4,1	7,2	6,1	10,5	8,3	13,2	11												
				24	2,5	5,3	6	8,7	9,5	11,9	12,5	14,9												
	2	MAN - MIN - MCN MCRN - MC2RN	MAE - MIE MCE - MCRE MC2CE	2	13,4	3,5	20,5	4,1	26,6	5	34	6,1	41	7,4	48	8,8								
				4	12,2	4,1	19	5,3	25,5	6,7	32,5	8,4	39,5	11										
2S	MAN - MIN MCN - MCRN MC2RN	MAE - MIE MCE - MCRE MC2CE	6	10,8	5,2	17,2	6,5	24	8	30,8	10,8	37,8	14,3											
			14	6	14	11,2	16	16,4	18															
	17	5	15,2	10,2	17,3																			
	20	2,5	16	7,5	19,5																			
4	MAN - MIN MCN - MCRN	MC2CE --	8	10	6	15	7	20	12															
16	8,5	10	13,5	14	19	19																		
24	6	13	11	18,5																				

PERFORMANCES

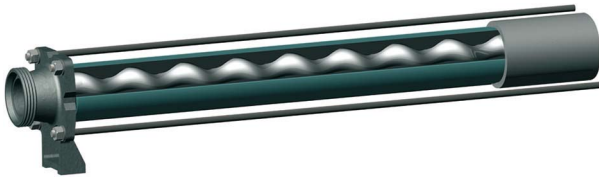

4 stages - max. 24 bar

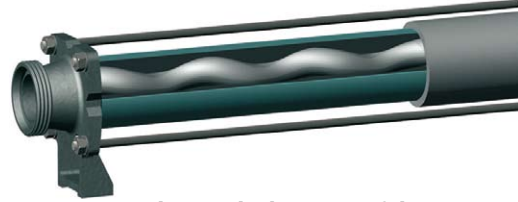

long pitch - max. 6 bar

h = Head, bar Q = Flow rate, m³/h Na = Power, HP n = rpm

Values referred to water at 20°C a.s.l.

Size	Stages	Version N	Version E	h	n=200		n=300		n=400		n=500		n=600		n=700		n=800		n=900		n=1000		n=1400			
					Q	Na	Q	Na	Q	Na	Q	Na	Q	Na	Q	Na	Q	Na	Q	Na	Q	Na	Q	Na	Q	Na
110	L	MAN - MIN MCN - MCRN MC2RN	MAE - MIE MCE - MCRE	2	22	4	35	5	45	6	57	8,5														
				4	20,5	5,5	31	8	42	11	53,5	13														
				6	19	7,5	29,5	11	40,5	14	51,5	18														
115	1	MAN - MIN MCN - MCRN	MAE - MIE MCE - MCRE	1	12	5	21	5,5	29	6	36	7														
				3	11	5,5	20	6,5	27	7,5	34	9														
				6	9	6	16	8	23	10	30	12														
115	2	MAN - MIN MCN - MCRN	MAE - MIE MCE - MCRE	4	14	7	22	8	29	9,5																
				8	13	8	20,5	10	27,5	13																
				12	12	10	19	13	26	16																
125	1	MAN - MIN MCN - MCRN MC2RN	MAE - MIE MCE - MCRE MC2CE	1	18,5	4,5	30	5,5	42	7,5	53	9,5														
				3	14	5,5	25,5	8,0	38	10,5																
				6	9	6,5	20	11,3																		
	2S	MAN - MIN MCN - MCRN MC2RN	MAE - MIE MCE - MCRE MC2CE	9	11	14,5	23	18,3	34,4	24																
				12	8	16,5	19	22	30	30																
				14	9,6	24	21	36	31	47																
4	MAN - MIN MCN - MCRN	MC2CE --	8	22	14	33	20	44	23																	
			16	20	20	31	29,5	41,5	39																	
			24	18	28	27,5	42																			
130	L	MAN - MIN MCN - MCRN MC2RN	MAE - MIE MCE - MCRE	2	29	6,1	44	8	59	10	74	12														
				4	26,8	8	42	11,9	57	15	72,5	19														
				6	23	10	38,4	15	54	20	69	25														
140	L	MIN - MCN MCRN	MIE - MCE MCRE	2	42	6,1	63,5	8,9																		
				4	41	9,2	62	11,7																		
				6	38,2	13,2	60	18,5																		
150	1	MIN - MCN MCRN	MIE - MCE MCRE	2	44	8	67	12	90	16	113	20														
				4	32	12	56	17	78	23	101	29														
				6	16	14,5	40	22	62	30	85	37														
	1S	MIN - MCN MCRN	MIE - MCE MCRE	1	44	10	70	12	93	16	115	21														
				4	40	12	62	18	85	26	105	38														
				8	31	20	52	30	72	42																
2	MIN - MCN MCRN	MIE - MCE MCRE	10	20	24	40	38																			
			4	44	8,8	67	14	92	19																	
			6	40,5	14,5	64	23	87	30,5																	
151	1,5	MIN - MCN MCRN	MIE - MCE MCRE	3	60	13	92	19	126	27																
				6	52	20	83	33	118	45																
				9	43	28	75	45	110	62																
160	L	MIN - MCN MCRN	MIE - MCE	2	86	10	132	16																		
				4	80	17	123	28																		
				6	75	24	115	42																		
200	2	MIN - MCN MCRN	--	4	77	22	126	40																		
				8	70	30	115	49																		
				12	60	41	104	66																		
	L	MIN - MCN MCRN	--	2	175	25	270	54																		
				4	150	36	250	33																		

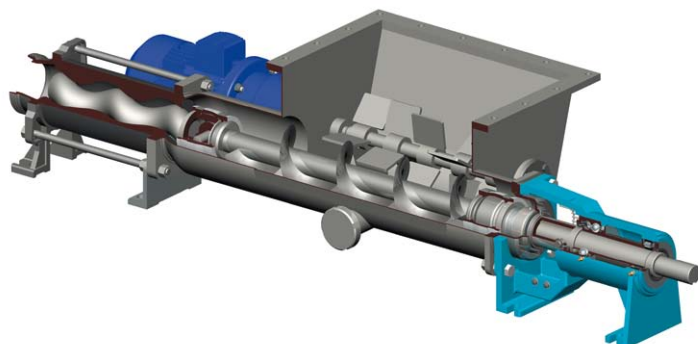
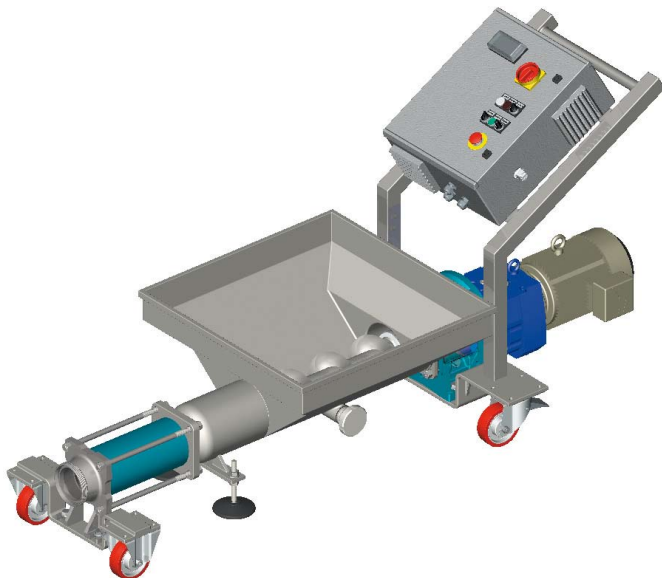

PERFORMANCES DOUBLE-THREAD VERSIONS

The new series of screw pumps offered together with the existent series is a logical evolution that derives from research made to optimise performance.

New shapes, additionally even structures, reduction of friction and greater volumes all enable improved performance.

They fit in with the existent series without dimensional modifications and are perfectly interchangeable.

This version of CSF screw pumps can be offered with a wide performance range to better meet all requirements.

In the new series the pump dimensions, assembly, drive, versions, constructional materials remain unaltered.

The following benefits are obtained:

- Greater mass = volume pumped
- Less eccentricity
- Less rotor mass
- Improved overall performance
- Lower internal speed, therefore improved flow rate
- Greater transversal pumping
- Even thickness of the elastomer wall, therefore less driving torque and therefore less absorbed power

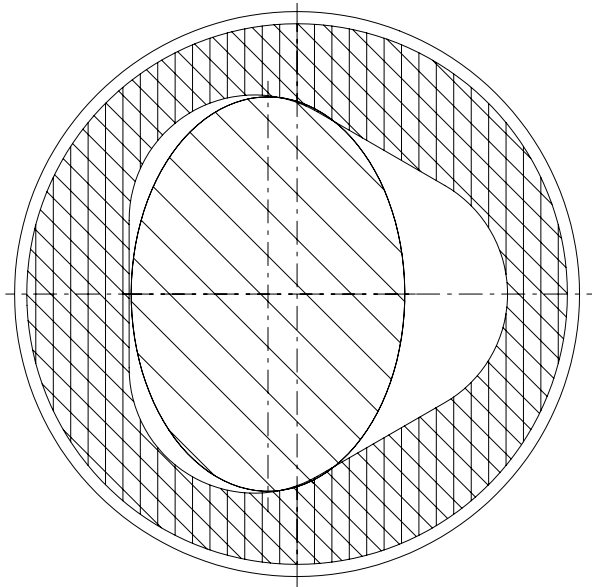

New shape of the rotor/stator
 Greater volumetric mass = volume pumped
 Improved performance
 Improved NPSH values

h = Head, bar Q = Flow rate, m³/h Na = Power, HP n = rpm

Values referred to water at 20°C a.s.l.

Size	Stages	Version N	Version E	h	n=200		n=300		n=400		n=500		n=600		n=700		n=800		n=900		n=1000		n=1400			
					Q	Na	Q	Na	Q	Na	Q	Na	Q	Na	Q	Na	Q	Na	Q	Na	Q	Na	Q	Na	Q	Na
					63	1	MAN - MIN MCN - MCRN MC2RN	MAE - MIE MCE - MCRE	1	3,7	1,1	5,6	1,2	7,4	1,3	9,2	1,4	11,1	1,5	12,9	1,8	14,7	2,1			
				2	3,6	1,2	5,4	1,4	7,2	1,5	8,9	1,8	10,7	2,1	12,5	2,6	14,2	3								
				4	3,3	1,7	5	1,8	6,6	2,2	8,3	2,7	10	3,5	11,7	4,4	13,4	5,4								
83	1	MAN - MIN MCN - MCRN MC2RN	MAE - MIE MCE - MCRE	1	6,5	1,8	10,1	2,1	11,8	2,3	17,5	3,4														
				2	6,4	2	9,8	2,6	11,7	3	16,8	4,2														
				4	6	2,3	9,4	3,2	13	4,4	16,4	6,5														
				6	5,6	2,6	9	4	12,6	5,6	15,9	7,6														
103	1	MAN - MIN MCN - MCRN MC2RN	MAE - MIE MCE - MCRE	1	14	2,8	21,1	3,5	28,5	4,6	35,4	6														
				2	12,6	3,6	19,9	4,2	26,9	5,6	33,9	7,3														
				4	11	4,5	18,2	5,5	25,4	7,2	32,5	9,5														

PUMP CODES GUIDE

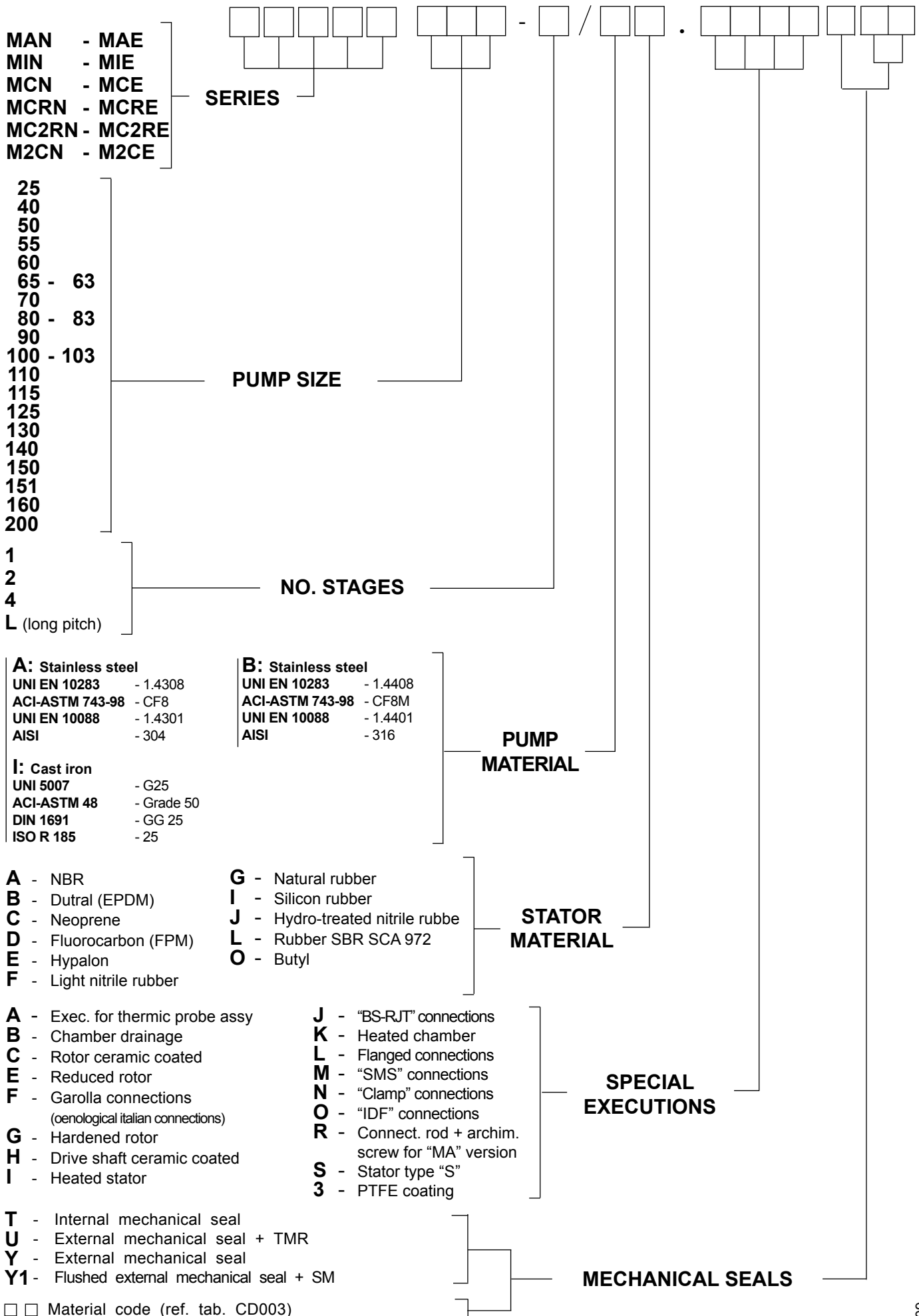

Example: **MAN 100-2/AF.ET32**

JOINT VERSIONS

TELESCOPIC ASSEMBLY TO FACILITATE PERIODIC PUMP CLEANING

VERSION N

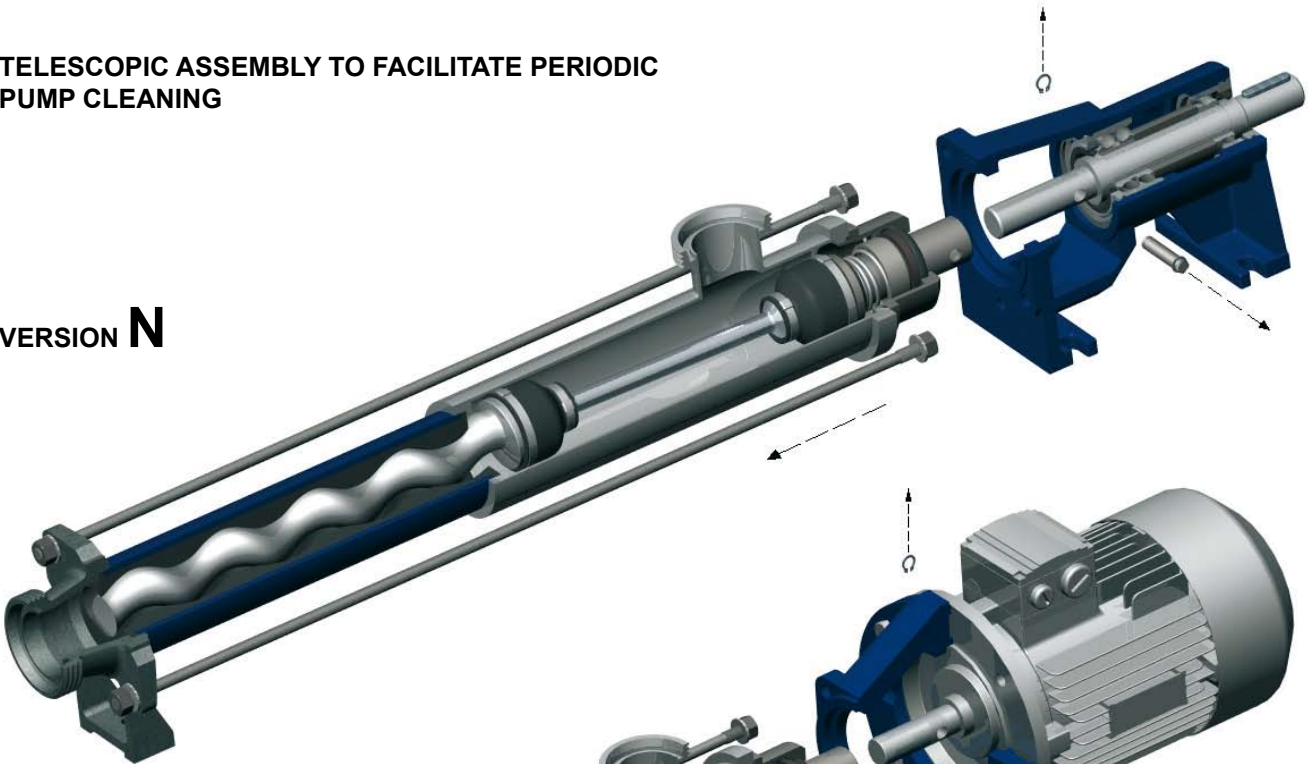

VERSION E

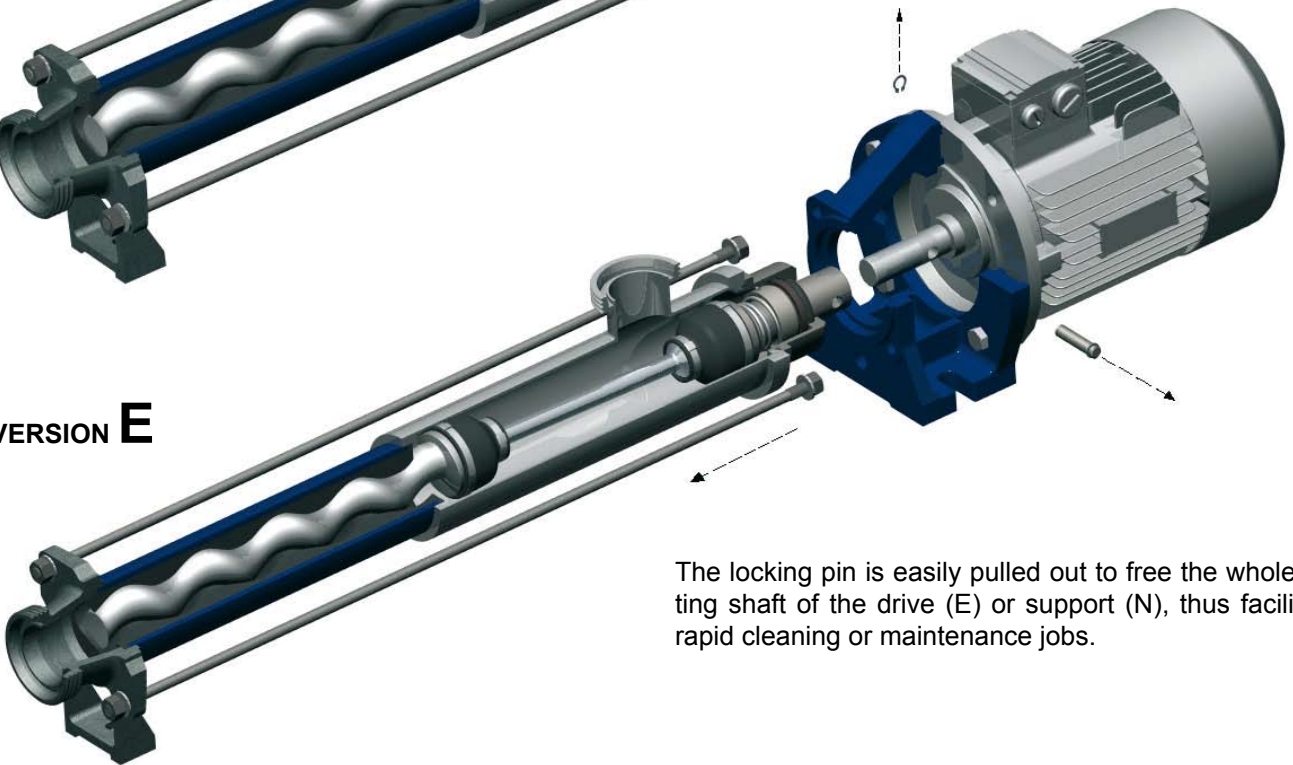

The locking pin is easily pulled out to free the whole rotating shaft of the drive (E) or support (N), thus facilitating rapid cleaning or maintenance jobs.

JOINTED JOINTS

In wear-resisting version with hardened bushes for heavy duty conditions and loads and safety sleeves.

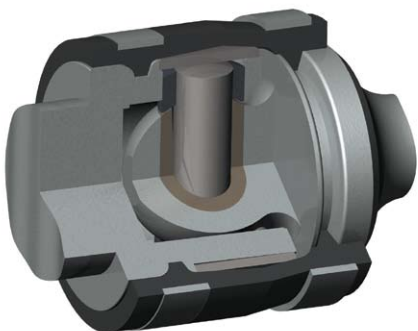

Execution from pump's size M 65 to M 200

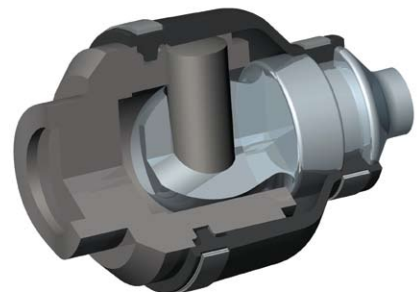

In sturdy stainless steel with OR seals or safety sleeves.

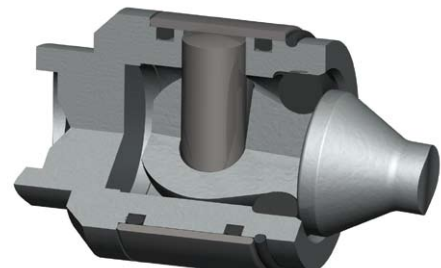

MECHANICAL SEALS

MATERIAL CODES

METALS

- H** - Nickel-plated stainless steel AISI 304
- X** - Stainless steel AISI 316L
- L** - Hastelloy (Ni alloy)

CARBONS

- V** - Normal carbon
- Z** - Special carbon

RESINS

- 5** - Normal PTFE
- F** - O-Ring FEP

METAL CARBONS

- 3** - Hard metal welded on stainless steel (TUC)
- R** - Integral anti-corrosion hard metal (TUC)
- K** - Integral silicate carbon (SIC)

ELASTOMERS

- 6** - Nitrile (NBR)
- 7** - Ethylene propylene (EPDM)
- Y** - Fluorocarbon (FPM)
- B** - Silicone

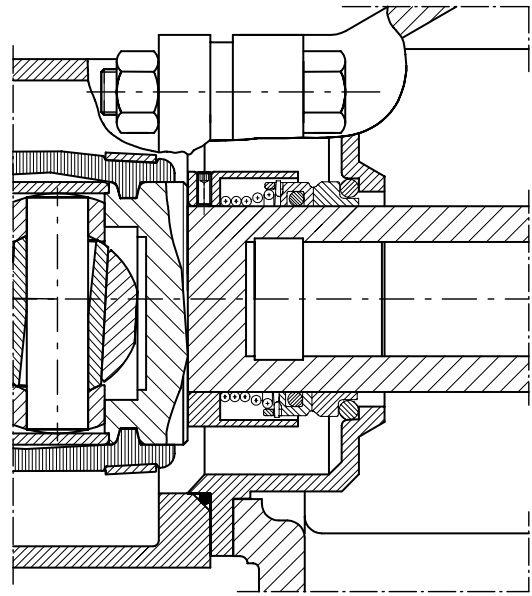
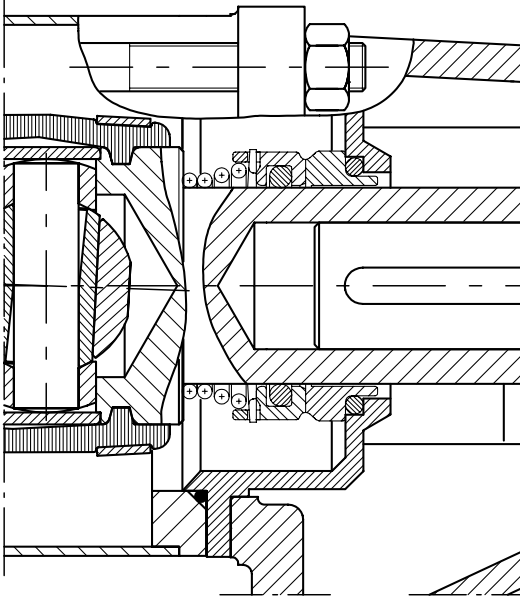

EXECUTION T



One direction



Reversible

Internal mechanical seal

The rotary mechanical seal is internal in order to ensure improved cooling and consequently to reduce its wear. The type of mechanical seal and the materials of the rotating surfaces and of the elastomers are chosen each time, among the several types available, according to the nature of the handled product.

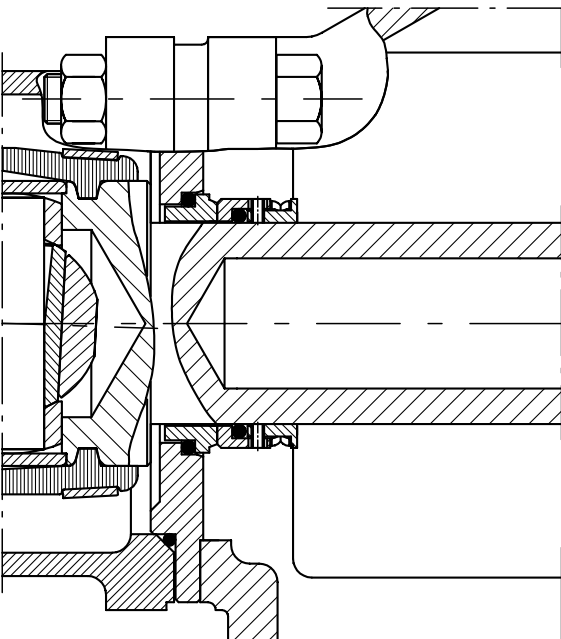

EXECUTION Y

External mechanical seal

For all cases for which the flushing is impossible and where the mechanical seal must not touch the pumped product, in order to avoid sanitary problems, corrosion and conditioning of its running.

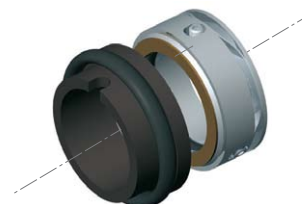

FLUSHED MECHANICAL SEALS

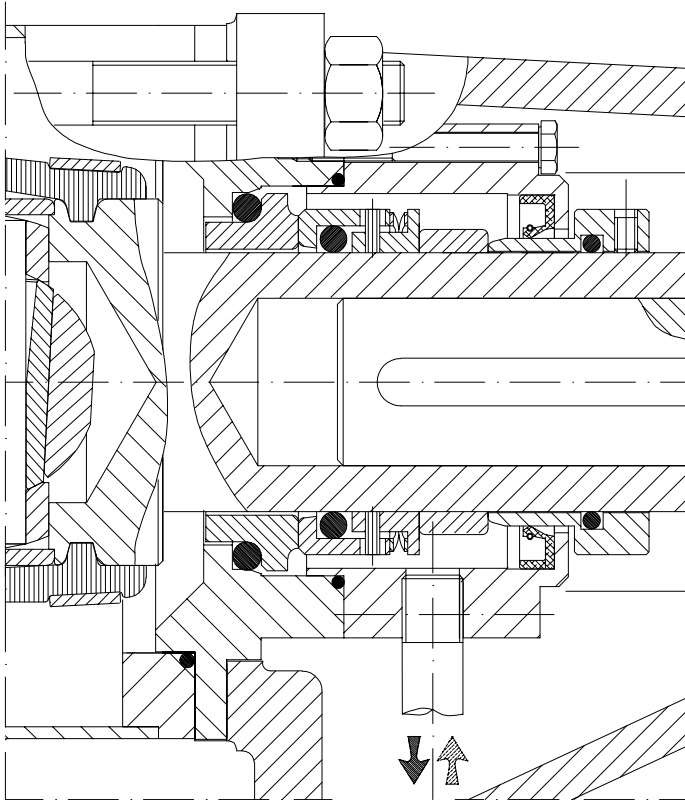

EXECUTION U - Y1

Double mechanical seal (U) Flushed mechanical seal (Y1)

Double mechanical seal with circulation of the cleaning and cooling liquid.

It is used with products that tend to crystallise, to glue, to harden, to be abrasive, to reach high temperatures and whenever the seal life is limited.

The function of the fluxing is to clean, lubricate and cool the seal; the circulating liquid must be clean and compatible with the pumped liquid.

If the seal is leaking the fluxing liquid will point out this fault.

The U execution is composed by an axial mechanical seal and a radial one working on ceramic coated shaft.

The Y1 execution is composed by an axial mechanical seal and a lip seal for the less heavy duty conditions.

Radial mech. seal

Mechanical seal



PACKED GLAND SEAL

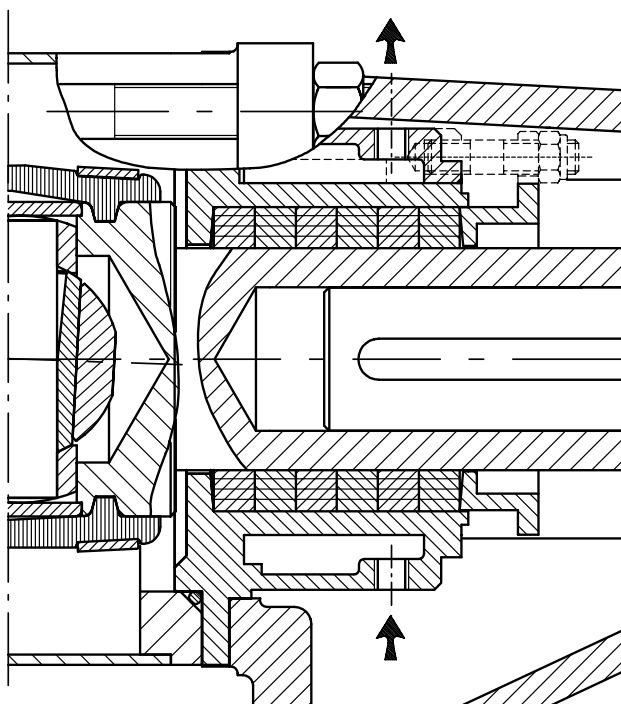

EXECUTION XT00

Cooled packed gland seal

Traditional solution in which a slight dripping does not disturb.



FB		<p>DIRECT MOTOR + FIXED BASE</p> <p>DIRECT MOTOR + INVERTER AND FIXED BASE</p>
FD		<p>MOTOR, PULLEY AND FIXED BASE</p>
FE		<p>GEAR MOTOR AND FIXED BASE</p> <p>GEAR MOTOR + INVERTER AND FIXED BASE</p>
FF		<p>MECHANICAL VARIABLE SPEED MOTOR AND FIXED BASE</p> <p>BELT VARIABLE SPEED MOTOR AND FIXED BASE</p>
F 1 B		<p>DIRECT MOTOR AND TROLLEY</p> <p>DIRECT MOTOR + INVERTER AND TROLLEY</p>
F 1 D		<p>MOTOR, PULLEY AND TROLLEY</p>
F 1 E		<p>GEAR MOTOR AND TROLLEY</p> <p>GEAR MOTOR + INVERTER AND TROLLEY</p>
F 1 F		<p>MECHANICAL VARIABLE SPEED MOTOR AND TROLLEY</p> <p>BELT VARIABLE SPEED MOTOR AND TROLLEY</p>
		<p>VERSION N</p> <p>Independent bench support with double grease lubricated bearings for coupling with flexible joint.</p>

F B

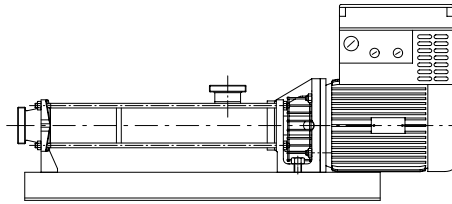
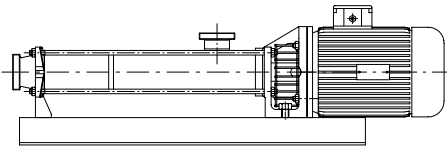

**DIRECT MOTOR +
FIXED BASE**

**DIRECT MOTOR + INVERTER
AND FIXED BASE**

F E

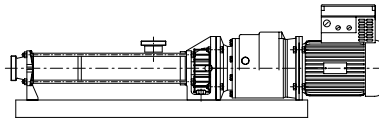
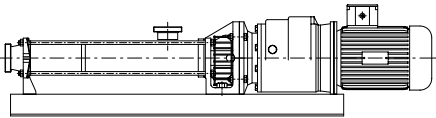

GEAR MOTOR AND FIXED BASE

**GEAR MOTOR + INVERTER AND
FIXED BASE**

F F

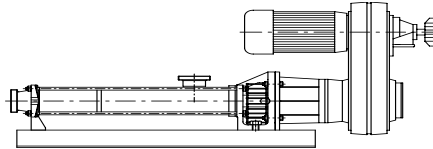
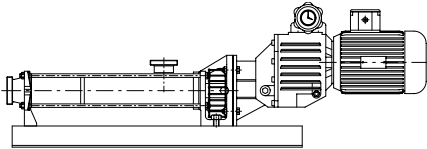

**MECHANICAL VARIABLE SPEED
MOTOR AND FIXED BASE**

**BELT VARIABLE SPEED MOTOR
AND FIXED BASE**

F 1 B

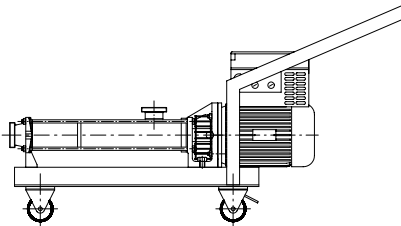
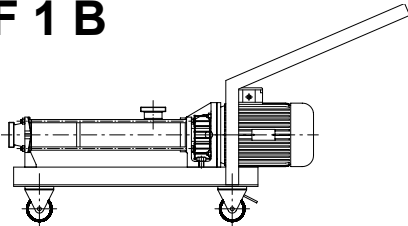

DIRECT MOTOR AND TROLLEY

**DIRECT MOTOR + INVERTER
AND TROLLEY**

F 1 E

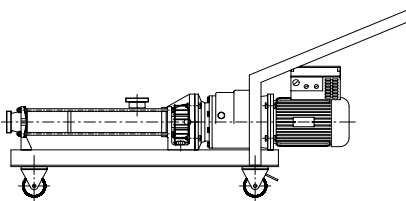
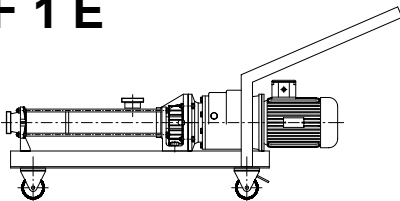

GEAR MOTOR AND TROLLEY

**GEAR MOTOR + INVERTER AND
TROLLEY**

F 1 F

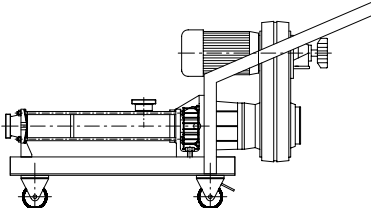
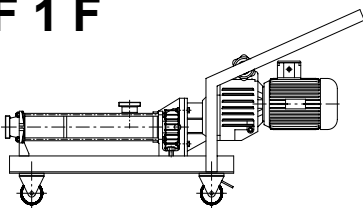

**MECHANICAL VARIABLE SPEED
MOTOR AND TROLLEY**

**BELT VARIABLE SPEED MOTOR
AND TROLLEY**

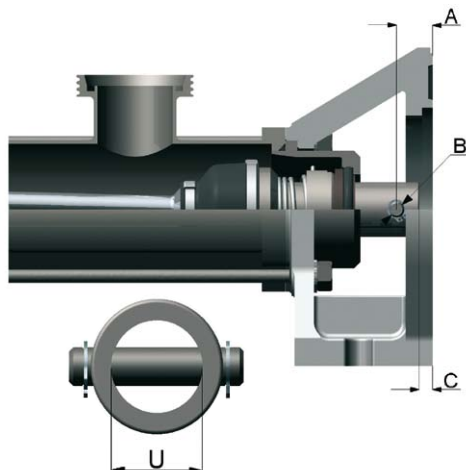

VERSION E

PUMP SHAFT - COUPLING DIMENSIONS

	TYPE								
	M 25	M 40	M 50 M 55 M 60L	M 63 M 65 M 70L	M 83 M 80 M 90L	M 100 M 103 M 110L M 115	M 125	M 130L M 140L	M 150 M 160L
A	15	20	25	25	26	30	32	32	32
B H7	6	8	10	14	16	16	18	18	18
C	=	=	10	10	10	10	10	10	10
U H7	14	19	24	32	35	42	55	55	55

ACCESSORIES

HOPPER LID



AUTOMATIC BY-PASS

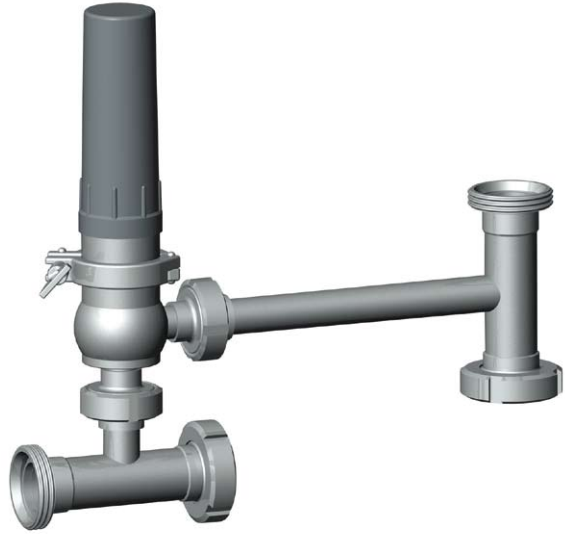

STATOR HEATING CHAMBER



MANUAL BY-PASS

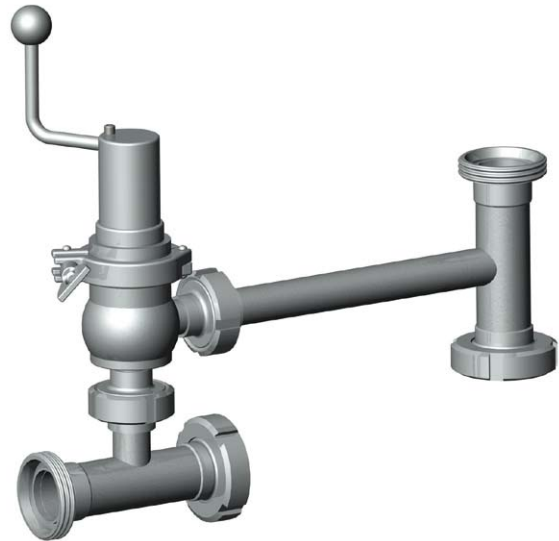

FLOW METER FOR SAFETY AGAINST DRY RUNNING



HEAT PROBE

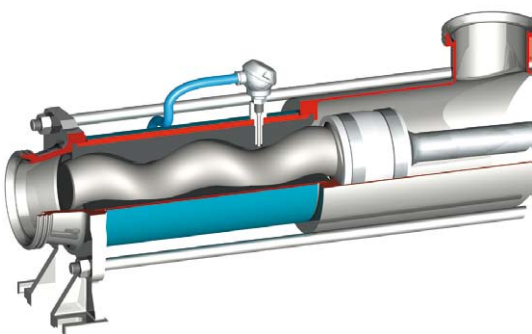

ELECTRICAL CONTROL PANEL



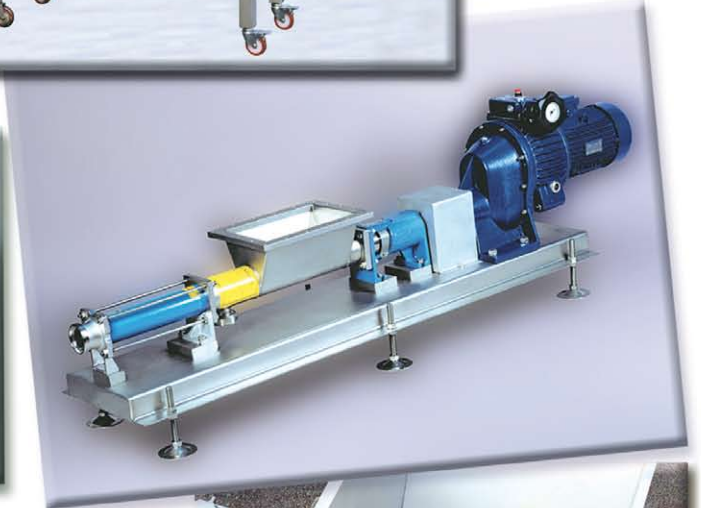
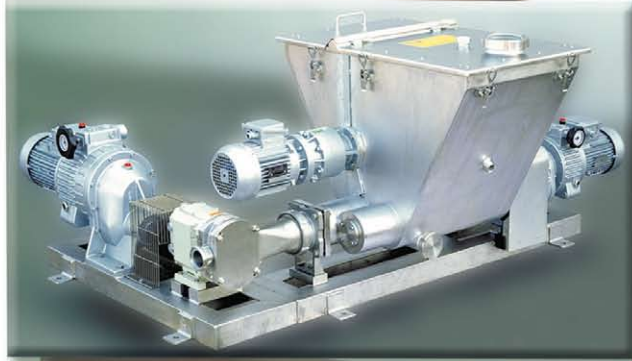

PROGRESSIVE CAVITY PUMPS DIMENSIONAL CATALOGUE

MAE

OVERALL DIMENSIONS

MAE 25

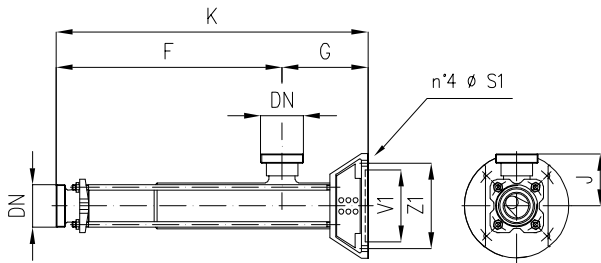

MAE 40

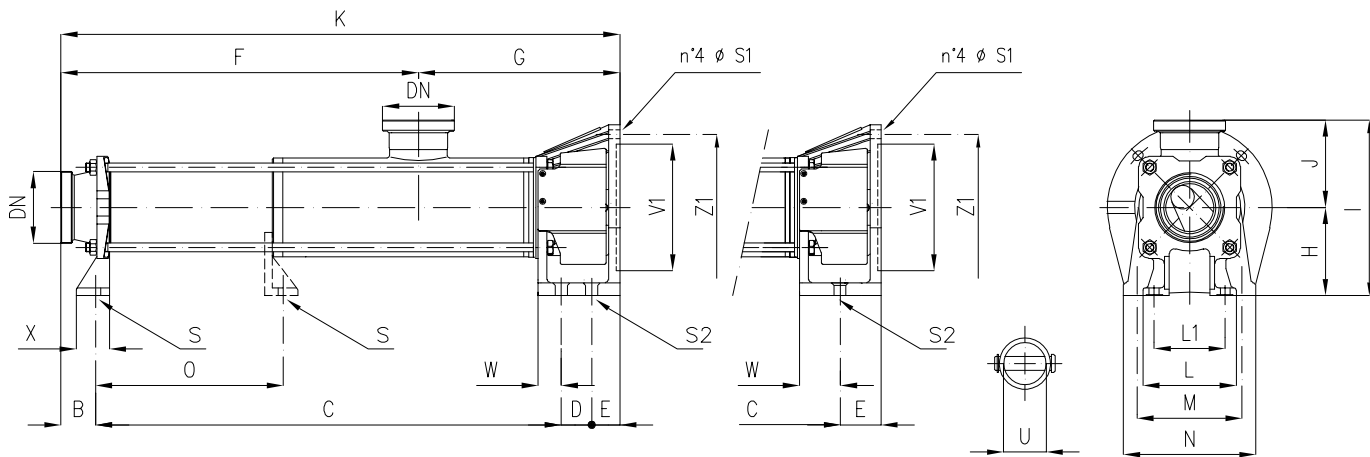
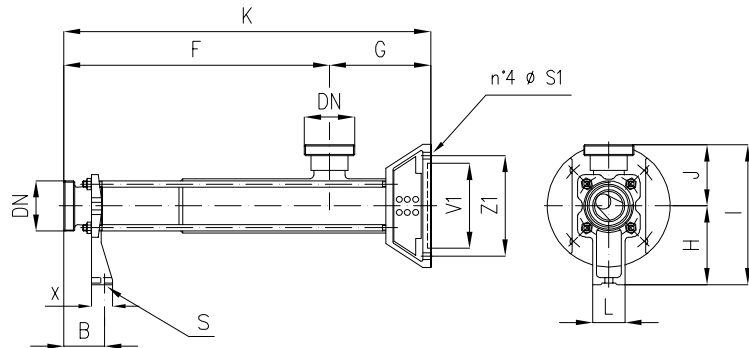

(**) To be determined according to the motorization used.

Dimensions not binding

TYPE	B	C	D	E	F	G	K	H	J	I	L	L1	M	N	O	DN	S	U	(**) V1	(**) Z1	S1	S2	X	W	Weight Kg
MAE 25-1	-	**	-	-	236	115	351	**	62	**	-	-	**	**	-	25	-	14	70	85	7	-	-	-	5
MAE 25-2	-	**	-	-	316	115	431	**	62	**	-	-	**	**	-	25	-	14	70	85	7	-	-	-	6
MAE 40-1	53	**	-	-	344	131	475	**	79	**	42	-	**	**	-	40	10	19	110	130	9	-	27	-	7
MAE 40-2	53	**	-	-	444	131	575	**	79	**	42	-	**	**	-	40	10	19	110	130	9	-	27	-	9
MAE 50-1	71	530	-	49	452	198	650	100	86	186	68	-	110	150	-	50	12	24	130	165	13	17	35	43	19
MAE 50-2	71	680	-	49	602	198	800	100	86	186	68	-	110	150	-	50	12	24	130	165	13	17	35	43	24
MAE 55-4	71	985	-	49	907	198	1105	100	86	186	68	-	110	150	-	50	12	24	130	165	13	17	35	43	-
MAE 60-L	71	697	-	49	619	198	817	100	86	186	68	-	110	150	-	50	12	24	130	165	13	17	35	43	-
MAE 65-1	71	572	-	59	438	264	702	125	113	238	88	-	140	180	-	65	14	32	180	215	14	19	35	52	32
MAE 63-1	71	572	-	59	438	264	702	125	113	238	88	-	140	180	-	65	14	32	180	215	14	19	35	52	32
MAE 65-2	71	772	-	59	638	264	902	125	113	238	88	-	140	180	353	65	14	32	180	215	14	19	35	52	38
MAE 65-4	71	1182	-	59	1048	264	1312	125	113	238	88	-	140	180	763	65	14	32	180	215	14	19	35	52	-
MAE 70-L	71	772	-	59	638	264	902	125	113	238	88	-	140	180	353	65	14	32	180	215	14	19	35	52	38
MAE 80-1	82	617,5	-	63	536	226,5	762,5	140	119,5	259,5	100	-	150	190	-	80	14	35	180	215	14	19	39	55	39
MAE 83-1	82	617,5	-	63	536	226,5	762,5	140	119,5	259,5	100	-	150	190	-	80	14	35	180	215	14	19	39	55	39
MAE 80-2	82	874	-	63	786	233	1019	140	132	272	100	-	150	190	448	80	14	35	180	215	14	19	39	55	50
MAE 80-4N	82	1492	-	63	1404	233	1637	140	132	272	100	-	150	190	970	80	14	35	180	215	14	19	39	55	-
MAE 90-L	82	944	-	63	856	233	1089	140	132	272	100	-	150	190	518	80	14	35	180	215	14	19	39	55	-
MAE 100-1	52,5	860,5	55	51	651	368	1019	160	158	318	185	145	190	240	-	100	18	42	230	265	16	18	60	42	75
MAE 103-1	52,5	860,5	55	51	651	368	1019	160	158	318	185	145	190	240	-	100	18	42	230	265	16	18	60	42	75
MAE 100-2	52,5	1166,5	55	51	957	368	1325	160	158	318	185	145	190	240	596	100	18	42	230	265	16	18	60	42	101
MAE 100-4N	52,5	1910,5	55	51	1719	350	2087	160	158	318	185	145	190	240	1225	100	18	42	230	265	16	18	60	42	-
MAE 110-L	52,5	1210,5	55	51	1001	368	1369	160	158	318	185	145	190	240	640	100	18	42	230	265	16	18	60	42	-
MAE 115-1	52,5	900,5	55	51	691	368	1059	160	158	318	185	145	190	240	-	100	18	42	230	265	16	18	60	42	-
MAE 115-2	52,5	1250,5	55	51	1041	368	1409	160	158	318	185	145	190	240	680	100	18	42	230	265	16	18	60	42	-
MAE 125-1	55	1079	67	50	814	437	1251	180	174	354	215	170	230	280	-	100	18	55	230 250	265 300	18	18	65	43	125
MAE 125-2	55	1479	67	50	1214	437	1651	180	174	354	215	170	230	280	786	100	18	55	230 250	265 300	18	18	65	43	165
MAE 130-L	55	1393	67	50	1128	437	1565	180	174	354	215	170	230	280	701	100	18	55	230 250	265 300	18	18	65	43	-

MAN

OVERALL DIMENSIONS

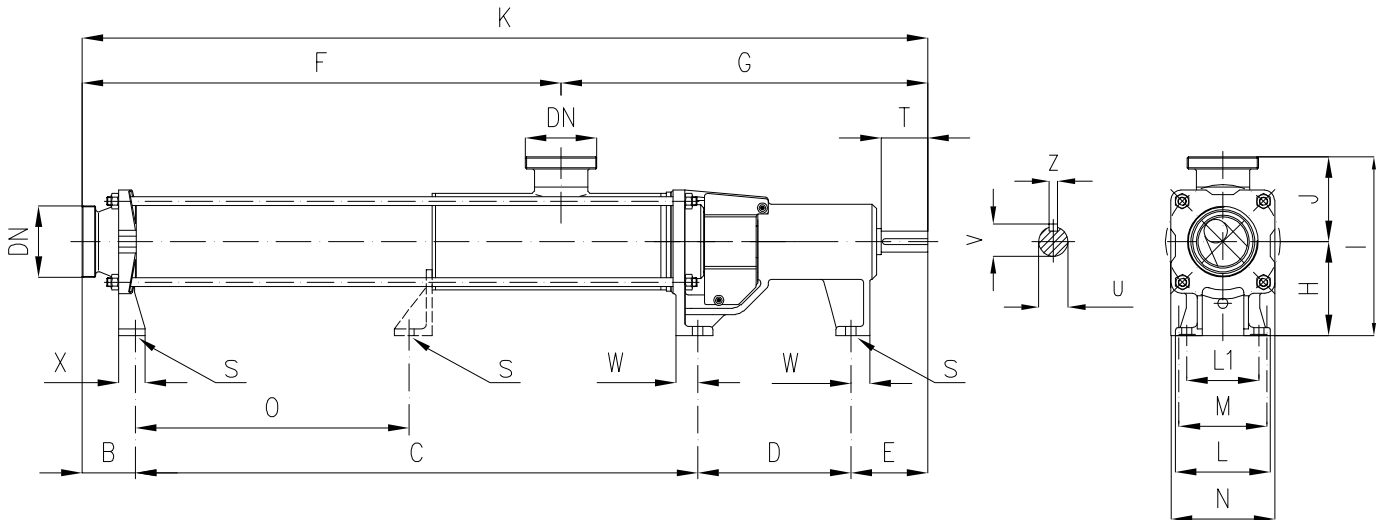

Dimensions not binding

TYPE	B	C	D	E	F	G	K	H	J	I	L	L1	M	N	O	DN	S	T	U	V	Z	X	W	Weight Kg
MAN 40-1	53	404	-	166	344	279	623	90	79	169	42	-	60	82	-	40	10	35	14	16	5	27	30	9
MAN 40-2	53	504	-	166	444	279	723	90	79	169	42	-	60	82	-	40	10	35	14	16	5	27	30	11
MAN 50-1	71	515	152	81	452	367	819	100	86	186	68	-	85	110	-	50	12	50	25	28	8	35	27	22
MAN 50-2	71	662	152	81	599	367	966	100	86	186	68	-	85	110	-	50	12	50	25	28	8	35	27	27
MAN 55-4	71	970	152	81	907	367	1274	100	86	186	68	-	85	110	-	50	12	50	25	28	8	35	27	-
MAN 60-L	71	678	152	81	615	367	982	100	86	186	68	-	85	110	-	50	12	50	25	28	8	35	27	-
MAN 65-1	71	549	204	102	438	488	926	125	113	238	88	-	108	138	-	65	14	62	28	31	8	35	25	35
MAN 63-1	71	549	204	102	438	488	926	125	113	238	88	-	108	138	-	65	14	62	28	31	8	35	25	35
MAN 65-2	71	749	204	102	638	488	1126	125	113	238	88	-	108	138	353	65	14	62	28	31	8	35	25	42
MAN 65-4	71	1159	204	102	1048	488	1536	125	113	238	88	-	108	138	763	65	14	62	28	31	8	35	25	-
MAN 70-L	71	749	204	102	638	488	1126	125	113	238	88	-	108	138	353	65	14	62	28	31	8	35	25	42
MAN 80-1	82	594	222	124	536	486	1022	140	120	260	100	-	115	155	-	80	14	75	35	38	10	39	34	49
MAN 83-1	82	594	222	124	536	486	1022	140	120	260	100	-	115	155	-	80	14	75	35	38	10	39	34	49
MAN 80-2	82	851	222	124	786	493	1279	140	132	272	100	-	115	155	448	80	14	75	35	38	10	39	34	60
MAN 80-4N	82	1469	222	124	1404	493	1897	140	132	272	100	-	115	155	970	80	14	75	35	38	10	39	34	-
MAN 90-L	82	921	222	124	856	493	1349	140	132	272	100	-	115	155	518	80	14	75	35	38	10	39	34	-
MAN 100-1	52,5	854,5	274	141	651	671	1322	160	158	318	185	145	145	185	-	100	18	90	42	45	12	60	35	94
MAN 103-1	52,5	854,5	274	141	651	671	1322	160	158	318	185	145	145	185	-	100	18	90	42	45	12	60	35	94
MAN 100-2	52,5	1160,5	274	141	957	671	1628	160	158	318	185	145	145	185	596	100	18	90	42	45	12	60	35	120
MAN 100-4N	52,5	1922,5	274	141	1719	671	2390	160	158	318	185	145	145	185	1233,5	100	18	90	42	45	12	60	35	-
MAN 110-L	52,5	1204,5	274	141	1001	671	1672	160	158	318	185	145	145	185	640	100	18	90	42	45	12	60	35	-
MAN 115-1	52,5	894,5	274	141	691	671	1362	160	158	318	185	145	145	185	-	100	18	90	42	45	12	60	35	-
MAN 115-2	52,5	1244,5	274	141	1041	671	1712	160	158	318	185	145	145	185	680	100	18	90	42	45	12	60	35	-
MAN 125-1	55	1079	318	167	814	805	1619	180	174	354	215	170	170	215	-	100	18	110	55	59	16	65	40	150
MAN 125-2	55	1479	318	167	1214	805	2019	180	174	354	215	170	170	215	786	100	18	110	55	59	16	65	40	190
MAN 125-4N	55	2380	318	167	2115	805	2920	180	174	354	215	170	170	215	1598,5	100	18	110	55	59	16	65	40	-
MAN 130-L	55	1393	318	167	1128	805	1933	180	174	354	215	170	170	215	701	100	18	110	55	59	16	65	40	-

MIE

OVERALL DIMENSIONS

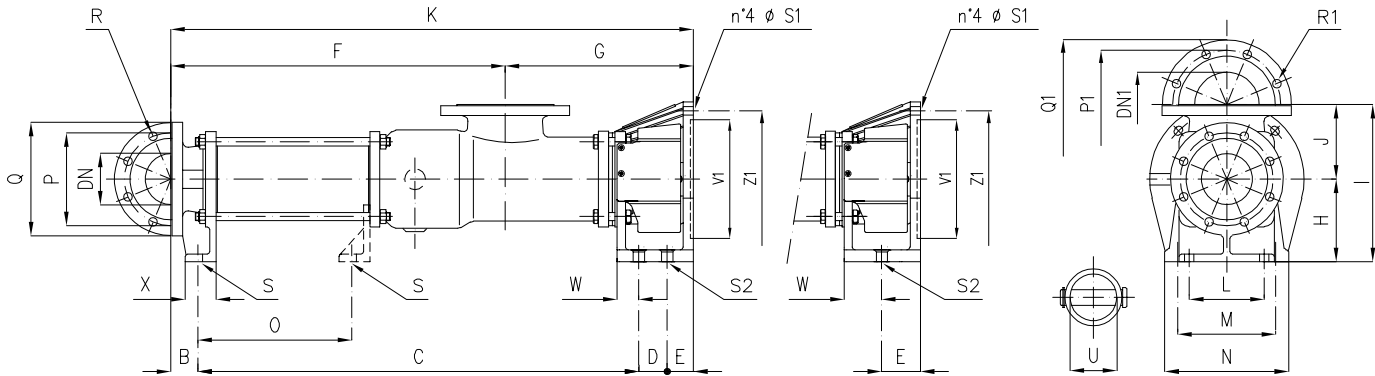

(**) To be determined according to the motorization used.

Dimensions not binding - EN 1092-1 PN16 flanges

TYPE	B	C	D	E	F	G	K	H	J	I	L	M	N	O	DN	P	Q	R	no. holes	DN1	P1	Q1	R1	no. holes	S	(**) S1	S2	U	(**) V1	(**) Z1	X	W	Weight Kg	
MIE 50-1	54	558	-	49	462	198	660	100	93	193	85	110	150	-	50	125	165	18	4	50	125	165	18	4	12	13	17	24	130	165	40	43	26	
MIE 50-2	54	708	-	49	612	198	810	100	93	193	85	110	150	-	50	125	165	18	4	50	125	165	18	4	12	13	17	24	130	165	40	43	30	
MIE 55-4	54	1015	-	49	920	198	1118	100	93	193	85	110	150	-	50	125	165	18	4	50	125	165	18	4	12	13	17	24	130	165	40	43	-	
MIE 60-L	54	723	-	49	628	198	826	100	93	193	85	110	150	-	50	125	165	18	4	50	125	165	18	4	12	13	17	24	130	165	40	43	-	
MIE 65-1	44	602	-	59	438	267	705	125	120	245	108	140	180	-	65	145	185	18	4	80	160	200	18	8	14	14	19	32	180	215	45	52	39	
MIE 63-1	44	802	-	59	638	267	905	125	120	245	108	140	180	382	65	145	185	18	4	80	160	200	18	8	14	14	19	32	180	215	45	52	-	
MIE 65-2	44	802	-	59	638	267	905	125	120	245	108	140	180	382	65	145	185	18	4	80	160	200	18	8	14	14	19	32	180	215	45	52	-	
MIE 65-4	44	1212	-	59	1048	267	1315	125	120	245	108	140	180	792	65	145	185	18	4	80	160	200	18	8	14	14	19	32	180	215	45	52	45	
MIE 70-L	44	802	-	59	638	267	905	125	120	245	108	140	180	382	65	145	185	18	4	80	160	200	18	8	14	14	19	32	180	215	45	52	45	
MIE 80-1	41	663	-	63	481	286	767	140	130	270	115	150	190	-	80	160	200	18	8	100	180	220	18	8	14	14	19	35	180	215	50	55	52	
MIE 83-1	41	913	-	63	731	286	1017	140	130	270	115	150	190	490	80	160	200	18	8	100	180	220	18	8	14	14	19	35	180	215	50	55	61	
MIE 80-2	41	913	-	63	731	286	1017	140	130	270	115	150	190	490	80	160	200	18	8	100	180	220	18	8	14	14	19	35	180	215	50	55	61	
MIE 80-4N	41	1531	-	63	1349	286	1635	140	130	270	115	150	190	1012	80	160	200	18	8	100	180	220	18	8	14	14	19	35	180	215	50	55	-	
MIE 90-L	41	983	-	63	801	286	1087	140	130	270	115	150	190	560	80	160	200	18	8	100	180	220	18	8	14	14	19	35	180	215	50	55	-	
MIE 100-1	52,5	854,5	55	51	648	365	1013	160	145	305	145	190	240	-	100	180	220	18	8	125	210	250	18	8	18	16	18	42	230	265	60	42	90	
MIE 103-1	52,5	1160,5	55	51	954	365	1319	160	145	305	145	190	240	596	100	180	220	18	8	125	210	250	18	8	18	16	18	42	230	265	60	42	116	
MIE 100-2	52,5	1925,5	55	51	1719	373	2084	160	145	305	145	190	240	1225	100	180	220	18	8	125	210	250	18	8	18	16	18	42	230	265	60	42	-	
MIE 110-L	52,5	1204,5	55	51	998	365	1363	160	145	305	145	190	240	640	100	180	220	18	8	125	210	250	18	8	18	16	18	42	230	265	60	42	-	
MIE 115-1	52,5	894,5	55	51	688	365	1053	160	145	305	145	190	240	-	100	180	220	18	8	125	210	250	18	8	18	16	18	42	230	265	60	42	-	
MIE 115-2	52,5	1244,5	55	51	1038	365	1403	160	145	305	145	190	240	680	100	180	220	18	8	125	210	250	18	8	18	16	18	42	230	265	60	42	-	
MIE 125-1	46,5	1079,5	67	50	806	437	1243	180	172	352	170	230	280	-	125	210	250	18	8	150	240	285	22	8	18	18	18	55	230	300	65	43	155	
MIE 125-2	46,5	1479,5	67	50	1206	437	1643	180	172	352	170	230	280	789,5	125	210	250	18	8	150	240	285	22	8	18	18	18	55	230	300	65	43	195	
MIE 130-L	46,5	1393,5	67	50	1120	437	1557	180	172	352	170	230	280	703,5	125	210	250	18	8	150	240	285	22	8	18	18	18	55	230	300	65	43	-	
MIE 140-L	46,5	1479,5	67	50	1206	437	1643	180	172	352	170	230	280	789,5	125	210	250	18	8	150	240	285	22	8	18	18	18	55	230	300	65	43	195	
MIE 150-1S	66	1881	70	50	1680	387	2067	200	210	410	200	200	250	509	150	240	285	22	8	150	240	285	22	8	22	16	20	22	55	230	300	90	75	-
MIE 150-2	66	2381	70	50	2180	387	2567	200	210	410	200	200	250	1009	150	240	285	22	8	150	240	285	22	8	22	16	20	22	55	230	300	90	75	-
MIE 151-1,5	56	2232	70	50	2021	387	2408	200	210	410	200	200	250	854	200	295	340	22	12	150	240	285	22	8	22	16	20	22	55	230	300	90	75	-
MIE 160-L	66	2375	70	50	2174	387	2561	200	210	410	200	200	250	1002	150	240	285	22	8	150	240	285	22	8	22	16	20	22	55	230	300	90	75	-

MIN

OVERALL DIMENSIONS

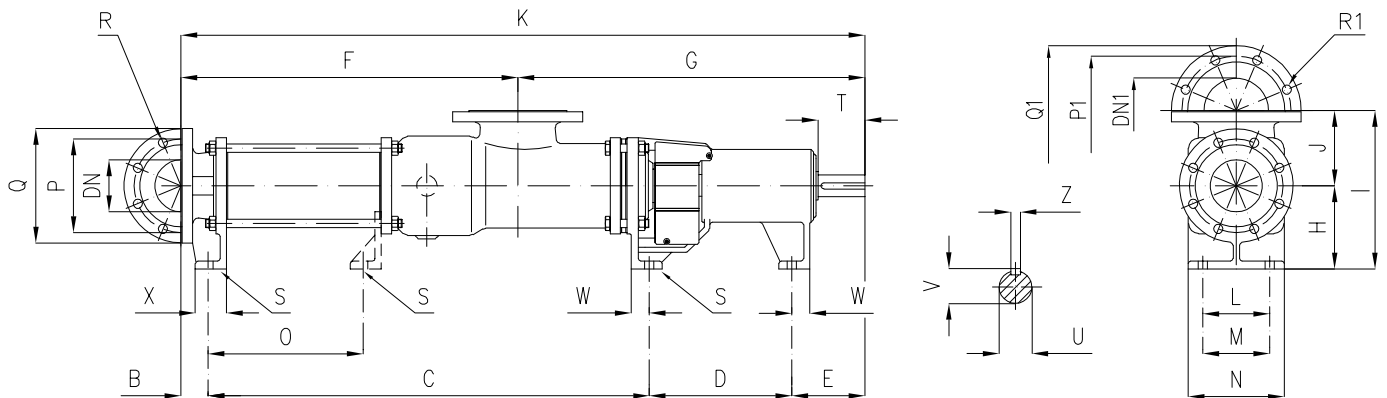

Dimensions not binding - EN 1092-1 PN16 flanges

TYPE	B	C	D	E	F	G	K	H	J	I	L	M	N	O	DN	P	Q	R	no. holes	DN1	P1	Q1	R1	no. holes	S	T	U	V	Z	X	W	Weight Kg
MIN 50-1	54	543	152	81	462	367	829	100	93	193	85	85	110	-	50	125	165	18	4	50	125	165	18	4	12	50	25	28	8	40	27	29
MIN 50-2	54	693	152	81	612	367	979	100	93	193	85	85	110	-	50	125	165	18	4	50	125	165	18	4	12	50	25	28	8	40	27	33
MIN 55-4	54	1000	152	81	920	367	1287	100	93	193	85	85	110	-	50	125	165	18	4	50	125	165	18	4	12	50	25	28	8	40	27	-
MIN 60-L	54	709	152	81	628	367	995	100	93	193	85	85	110	-	50	125	165	18	4	50	125	165	18	4	12	50	25	28	8	40	27	-
MIN 65-1	44	579	204	102	438	491	929	125	120	245	108	108	138	-	65	145	185	18	4	80	160	200	18	8	14	62	28	31	8	45	25	42
MIN 65-2	44	779	204	102	638	491	1129	125	120	245	108	108	138	385	65	145	185	18	4	80	160	200	18	8	14	62	28	31	8	45	25	49
MIN 65-4	44	1189	204	102	1048	491	1539	125	120	245	108	108	138	795	65	145	185	18	4	80	160	200	18	8	14	62	28	31	8	45	25	-
MIN 70-L	44	779	204	102	638	491	1129	125	120	245	108	108	138	385	65	145	185	18	4	80	160	200	18	8	14	62	28	31	8	45	25	49
MIN 80-1	41	640,5	222	123,5	481	546	1027	140	130	270	115	115	155	-	80	160	200	18	8	100	180	220	18	8	14	75	35	38	10	50	34	59
MIN 80-2	41	890,5	222	123,5	731	546	1277	140	130	270	115	115	155	490	80	160	200	18	8	100	180	220	18	8	14	75	35	38	10	50	34	70
MIN 80-4N	41	1508,5	222	123,5	1349	546	1895	140	130	270	115	115	155	1012	80	160	200	18	8	100	180	220	18	8	14	75	35	38	10	50	34	-
MIN 90-L	41	960,5	222	123,5	801	546	1347	140	130	270	115	115	155	560	80	160	200	18	8	100	180	220	18	8	14	75	35	38	10	50	34	-
MIN 100-1	52,5	848,5	274	141	648	668	1316	160	145	305	145	145	185	-	100	180	220	18	8	125	210	250	18	8	18	90	42	45	12	60	35	110
MIN 100-2	52,5	1154,5	274	141	954	668	1622	160	145	305	145	145	185	596	100	180	220	18	8	125	210	250	18	8	18	90	42	45	12	60	35	136
MIN 100-4N	52,5	1922	274	141	1719	668	2390	160	158	318	145	145	185	1233,5	100	180	220	18	8	125	210	250	18	8	18	90	42	45	12	60	35	-
MIN 110-L	52,5	1198,5	274	141	998	668	1666	160	145	305	145	145	185	640	100	180	220	18	8	125	210	250	18	8	18	90	42	45	12	60	35	-
MIN 115-1	52,5	888,5	274	141	688	668	1356	160	145	305	145	145	185	-	100	180	220	18	8	125	210	250	18	8	18	90	42	45	12	60	35	-
MIN 115-2	52,5	1238,5	274	141	1038	668	1706	160	145	305	145	145	185	680	100	180	220	18	8	125	210	250	18	8	18	90	42	45	12	60	35	-
MIN 125-1	47	1079,5	318	167	806	805	1611	180	172	352	170	170	215	-	125	210	250	18	8	150	240	285	22	8	18	110	55	59	16	65	40	180
MIN 125-2	47	1484	318	167	1211	805	2016	180	172	352	170	170	215	792	125	210	250	18	8	150	240	285	22	8	18	110	55	59	16	65	40	220
MIN 125-4N	47	2385	318	167	2109	805	2916	180	172	352	170	170	215	1601	125	210	250	18	8	150	240	285	22	8	18	110	55	59	16	65	40	-
MIN 130-L	47	1393,5	318	167	1120	805	1925	180	172	352	170	170	215	703,5	125	210	250	18	8	150	240	285	22	8	18	110	55	59	16	65	40	-
MIN 140-L	47	1484	318	167	1211	805	2016	180	172	352	170	170	215	792	125	210	250	18	8	150	240	285	22	8	18	110	55	59	16	65	40	220
MIN 150-1S	66	1894	298	177	1680	755	2435	200	210	410	200	200	250	509	150	240	285	22	8	150	240	285	22	8	22	110	55	59	16	90	50	265
MIN 150-2	66	2394	298	177	2180	755	2935	200	210	410	200	200	250	1009	150	240	285	22	8	150	240	285	22	8	22	110	55	59	16	90	50	-
MIN 151-1,5	56	2245	298	177	2021	755	2776	200	210	410	200	200	250	854	200	295	340	22	12	150	240	285	22	12	22	110	55	59	16	90	50	-
MIN 160-L	66	2388	298	177	2174	755	2929	200	210	410	200	200	250	1003	150	240	285	22	8	150	240	285	22	8	22	110	55	59	16	90	50	-
MIN 200-2	246	2814	260	216	2741	794	3535	230	255	485	190	240	300	1224	200	295	340	22	12	200	295	340	22	12	22	130	65	69	18	87	60	540
MIN 200-L	246	2814	260	216	2741	794	3535	230	255	485	190	240	300	1224	200	295	340	22	12	200	295	340	22	12	22	130	65	69	18	87	60	540

OVERALL DIMENSIONS

MCE

HOPPER AND PRE-FEEDING SCREW

TYPE	A	A1	P1	P2	Q1	Q2	Q3	R1	no. holes
MCE 25-1	240	170	74	75	22	10	9	9	10
MCE 25-2	240	170	74	75	22	10	9	9	10
MCE 40-1	300	210	70	63,3	27,5	10	10	9	14
MCE 40-2	300	210	70	63,3	27,5	10	10	9	14
MCE 50-1	365	250	69	57,5	32,5	10	10	11	18
MCE 50-2	365	250	69	57,5	32,5	10	10	11	18
MCE 55-4	365	250	69	57,5	32,5	10	10	11	18
MCE 60-L	365	250	69	57,5	32,5	10	10	11	18
MCE 65-1	426	260	130	116	43	14	18	13	10
MCE 65-2	426	260	130	116	43	14	18	13	10
MCE 65-4	426	260	130	116	43	14	18	13	10
MCE 70-L	426	260	130	116	43	14	18	13	10
MCE 80-1	486	326	113	146	43	17	17	13	12
MCE 80-2	486	326	113	146	43	17	17	13	12
MCE 80-4	486	326	113	146	43	17	17	13	12

TYPE	A	A1	P1	P2	Q1	Q2	Q3	R1	no. holes
MCE 90-L	486	326	113	146	43	17	17	13	12
MCE 100-1	586	340	110	103	43	15	18	13	16
MCE 103-1	586	340	110	103	43	15	18	13	16
MCE 100-2	586	340	110	103	43	15	18	13	16
MCE 110-L	586	340	110	103	43	15	18	13	16
MCE 115-1	586	340	110	103	43	15	18	13	16
MCE 115-2	586	340	110	103	43	15	18	13	16
MCE 125-1	756	420	102	96	53	18	21	18	22
MCE 125-2	756	420	102	96	53	18	21	18	22
MCE 130-L	756	420	102	96	53	18	21	18	22
MCE 140-L	756	420	102	96	53	18	21	18	22
MCE150-1S	760	510	102	92	55	25	23	18	24
MCE 150-2	760	510	102	92	55	25	23	18	24
MCE151-1,5	760	510	102	92	55	25	23	18	24
MCE 160-L	760	510	102	92	55	25	23	18	24

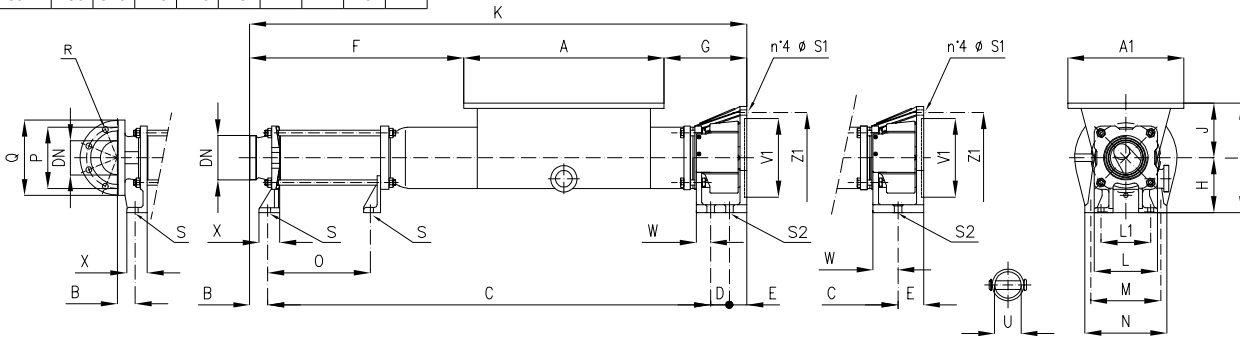
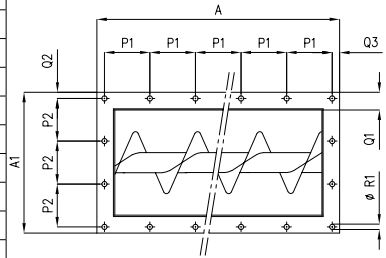

(*) The first parameter refers to a pump with outlet with EN 1092-1 PN16 flange; the second parameter refers to a pump with outlet with DIN 11851 male threaded connection.
 (**) To be determined according to the motorization used.

Dimensions not binding

TYPE	(*) B	(*) C	D	E	(*) F	G	(*) K	H	J	I	(*) L	L1	M	N	(*) O	(*) DN	P	Q	R	no. holes	S	U	(**) V1	(**) Z1	(**) S1	S2	(*) X	W	Weight Kg
MCE 25-1	105	**	-	-	162	54	456	**	80	**	160	60	**	**	-	25	-	-	-	-	10	14	70	85	7	-	35	-	-
MCE 25-2	193,5	**	-	-	250	54	544	**	80	**	160	60	**	**	-	25	-	-	-	-	10	14	70	85	7	-	35	-	-
MCE 40-1	53	**	-	-	261,5	95,5	657	**	100	**	-	-	**	**	-	40	-	-	-	-	10	19	110	130	9	-	27	-	-
MCE 40-2	53	**	-	-	361,5	95,5	757	**	100	**	-	-	**	**	-	40	-	-	-	-	10	19	110	130	9	-	27	-	-
MCE 50-1	71	733	-	49	353,5	134,5	853	100	125	225	68/68	85	110	150	102	50	125	165	18	4	12	24	130	165	13	17	35	43	28
MCE 50-2	71	883	-	49	503,5	134,5	1003	100	125	225	68/68	85	110	150	252	50	125	165	18	4	12	24	130	165	13	17	35	43	33
MCE 55-4	71	1189	-	49	809,5	134,5	1309	100	125	225	68/68	85	110	150	558	50	125	165	18	4	12	24	130	165	13	17	35	43	-
MCE 60-L	71	899	-	49	519,5	134,5	1019	100	125	225	68/68	85	110	150	268	50	125	165	18	4	12	24	130	165	13	17	35	43	-
MCE 65-1	44	916	-	59	439,5	153,5	1019	125	125	250	138/88	108	140	180	182/152	65	145	185	18	4	14	32	180	215	14	19	45/35	52	44
MCE 63-1	71	886	-	59	436,5	153,5	1016	125	125	250	138/88	108	140	180	382/352	65	145	185	18	4	14	32	180	215	14	19	45/35	52	50
MCE 65-2	44	1116	-	59	639,5	153,5	1219	125	125	250	138/88	108	140	180	792/762	65	145	185	18	4	14	32	180	215	14	19	45/35	52	-
MCE 65-4	44	1526	-	59	1049,5	153,5	1629	125	125	250	138/88	108	140	180	792/762	65	145	185	18	4	14	32	180	215	14	19	45/35	52	-
MCE 70-L	44	1116	-	59	639,5	153,5	1219	125	125	250	138/88	108	140	180	382/352	65	145	185	18	4	14	32	180	215	14	19	45/35	52	50
MCE 80-1	41	1027	-	63	489	156	1131	140	140	280	155/100	115	150	190	238/198	80	160	200	18	8	14	35	180	215	14	19	50/39	55	57
MCE 83-1	82	988	-	63	491	156	1133	140	140	280	155/100	115	150	190	488/448	80	160	200	18	8	14	35	180	215	14	19	50/39	55	68
MCE 80-2	41	1277	-	63	739	156	1381	140	140	280	155/100	115	150	190	1010/970	80	160	200	18	8	14	35	180	215	14	19	50/39	55	-
MCE 80-4	41	1799	-	63	1261	156	1903	140	140	280	155/100	115	150	190	1010/970	80	160	200	18	8	14	35	180	215	14	19	50/39	55	-
MCE 80-2	41	1238	-	63	741	156	1383	140	140	280	155/100	115	150	190	558/518	80	160	200	18	8	14	35	180	215	14	19	50/39	55	-
MCE 80-4	41	1799	-	63	1263	156	1905	140	140	280	155/100	115	150	190	558/518	80	160	200	18	8	14	35	180	215	14	19	50/39	55	-
MCE 90-L	41	1347	-	63	809	156	1451	140	140	280	155/100	115	150	190	558/518	80	160	200	18	8	14	35	180	215	14	19	50/39	55	-
MCE 100-1	52,5	1295,5	55	51	626	242	1454	160	160	320	185/185	145	190	240	290	100	180	220	18	8	18	42	230	265	16	18	60	42	98
MCE 103-1	52,5	1601,5	55	51	932	242	1760	160	160	320	185/185	145	190	240	596	100	180	220	18	8	18	42	230	265	16	18	60	42	124
MCE 100-2	52,5	2498,5	55	51	1809	257	2657	160	160	320	185/185	145	190	240	1225	100	180	220	18	8	18	42	230	265	16	18	60	42	-
MCE 110-L	52,5	1645,5	55	51	976	242	1804	160	160	320	185/185	145	190	240	640	100	180	220	18	8	18	42	230	265	16	18	60	42	-
MCE 115-1	52,5	1335,5	55	51	666	242	1494	160	160	320	185/185	145	190	240	330	100	180	220	18	8	18	42	230	265	16	18	60	42	-
MCE 115-2	52,5	1685,5	55	51	1016	242	1844	160	160	320	185/185	145	190	240	680	100	180	220	18	8	18	42	230	265	16	18	60	42	-
MCE 125-1	46,5	1659,5	67	50	807	260	1823	180	180	360	215/215	170	230	280	387,5	125/100	210	250	18	8	18	55	230/250	265/300	18	18	65	43	156
MCE 125-2	46,5	2059,5	67	50	1207	260	2223	180	180	360	215/215	170	230	280	787,5	125/100	210	250	18	8	18	55	230/250	265/300	18	18	65	43	196
MCE 130-L	46,5	1973,5	67	50	1121	260	2137	180	180	360	215/215	170	230	280	701,5	125/100	210	250	18	8	18	55	230/250	265/300	18	18	65	43	-
MCE 140-L	46,5	2059,5	67	50	1207	260	2223	180	180	360	215/215	170	230	280	787,5	125	210	250	18	8	18	55	230/250	265/300	18	18	65	43	196
MCE150-1S	66	1881	70	50	1025	282	2067	200	200	400	250	200	200	250	509	150	240	285	22	8	22	55	230/250	265/300	16/20	22	90	75	-
MCE 150-2	66	2381	70	50	1525	282	2567	200	200	400	250	200	200	250	1009	150	240	285	22	8	22	55	230/250	265/300	16/20	22	90	75	-
MCE151-1,5	56	2232	70	50	1376	282	2408	200	200	400	250	200	200	250	854	200	295	340	22	12	22	55	230/250	265/300	16/20	22	90	75	-
MCE 160-L	66	2374	70	50	1518	282	2560	200	200	400	250	200	200	250	1002	150	240	285	22	8	22	55	230/250	265/300	16/20	22	90	75	-

OVERALL DIMENSIONS

MCRE

HOPPER, PRE-FEEDING SCREW AND VANE CRUSHER

TYPE	A	A1	P1	P2	Q1	Q2	Q3	R1	no. holes
MCRE 50-1	365	443	102,5	85	32,5	12,5	16,5	13	16
MCRE 50-2	365	443	102,5	85	32,5	12,5	16,5	13	16
MCRE 55-4	365	443	102,5	85	32,5	12,5	16,5	13	16
MCRE 60-L	365	443	102,5	85	32,5	12,5	16,5	13	16
MCRE 65-1	426	565	105	130	42,5	18	20	13	16
MCRE 63-1	426	565	105	130	42,5	18	20	13	16
MCRE 65-2	426	565	105	130	42,5	18	20	13	16
MCRE 65-4	426	565	105	130	42,5	18	20	13	16
MCRE 70-L	426	565	105	130	42,5	18	20	13	16
MCRE 80-1	486	580	110	113	43	17	15	13	18
MCRE 83-1	486	580	110	113	43	17	15	13	18
MCRE 80-2	486	580	110	113	43	17	15	13	18
MCRE 80-4	486	580	110	113	43	17	15	13	18
MCRE 90-L	486	580	110	113	43	17	15	13	18

TYPE	A	A1	P1	P2	Q1	Q2	Q3	R1	no. holes
MCRE 100-1	586	564	106	110	43	18	16	13	20
MCRE 103-1	586	564	106	110	43	18	16	13	20
MCRE 100-2	586	564	106	110	43	18	16	13	20
MCRE 110-L	586	564	106	110	43	18	16	13	20
MCRE 115-1	586	564	106	110	43	18	16	13	20
MCRE 115-2	586	564	106	110	43	18	16	13	20
MCRE 125-1	756	642	120	102	53	21	21	16	24
MCRE 125-2	756	642	120	102	53	21	21	16	24
MCRE 130-L	756	642	120	102	53	21	21	16	24
MCRE 140-L	756	642	120	102	53	21	21	16	24
MCRE 150-1S	760	782	92	102	55	23	23	18	30
MCRE 150-2	760	782	92	102	55	23	23	18	30
MCRE 151-1,5	760	782	92	102	55	23	23	18	30

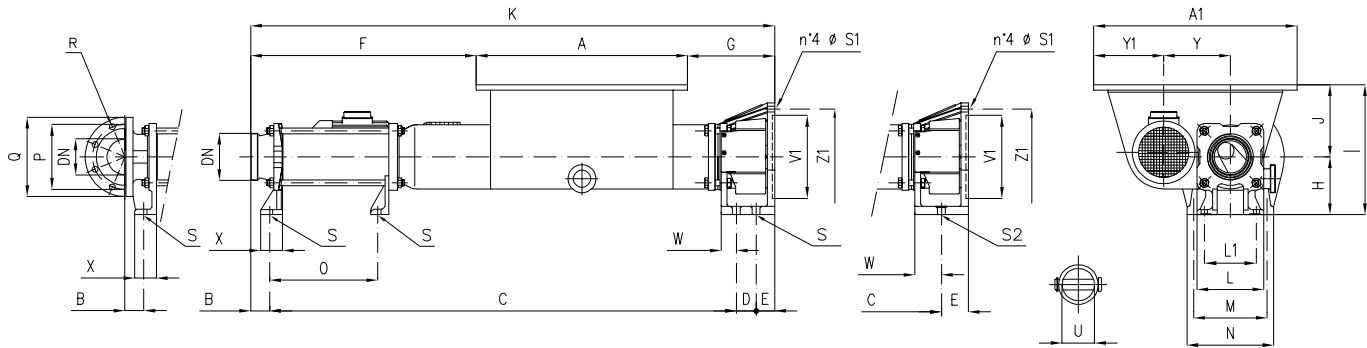
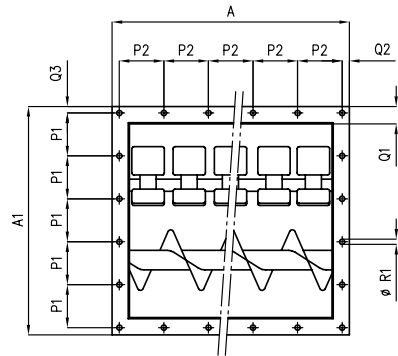

(*) The first parameter refers to a pump with outlet with EN 1092-1 PN16 flange; the second parameter refers to a pump with outlet with DIN 11851 male threaded connection.
 (**) To be determined according to the motorization used.

Dimensions not binding

TYPE	(*) B	(*) C	D	E	(*) F	G	(*) K	H	J	I	(*) L	(*) L1	M	N	(*) O	(*) DN	P	Q	R	no. holes	S	U	(**) V1	(**) Z1	(**) S1	S2	(*) Y	Y1	W	Weight Kg	
MCRE 50-1	71	733	-	49	353,5	134,5	853	100	160	260	68	85	110	150	102	50	-	-	-	-	12	24	130	165	13	17	35	139	166	43	-
MCRE 50-2	71	883	-	49	503,5	134,5	1003	100	160	260	68	85	110	150	252	50	125	165	18	4	12	24	130	165	13	17	35	139	166	43	-
MCRE 55-4	71	1189	-	49	809,5	134,5	1309	100	160	260	68	85	110	150	558	50	125	165	18	4	12	24	130	165	13	17	35	139	166	43	-
MCRE 60-L	71	899	-	49	519,5	134,5	1019	100	160	260	68	85	110	150	268	50	125	165	18	4	12	24	130	165	13	17	35	139	166	43	-
MCRE 65-1	71	886	-	59	436	154	1016	125	165	290	88	108	140	180	152	65	-	-	-	-	14	32	180	215	14	19	35	160	212,5	52	89
MCRE 63-1	44	1116	-	59	639	154	1219	125	165	290	88	108	140	180	382	65	145	185	18	4	14	32	180	215	14	19	45	160	212,5	52	96
MCRE 65-2	71	1086	-	59	636	154	1216	125	165	290	88	108	140	180	352	65	145	185	18	4	14	32	180	215	14	19	45	160	212,5	52	96
MCRE 65-4	44	1526	-	59	1049	154	1629	125	165	290	88	108	140	180	793	65	145	185	18	4	14	32	180	215	14	19	45	160	212,5	52	-
MCRE 70-L	44	1116	-	59	639	154	1219	125	165	290	88	108	140	180	382	65	145	185	18	4	14	32	180	215	14	19	45	160	212,5	52	96
MCRE 80-1	41	1027	-	63	489	156	1131	140	180	320	100	115	150	190	238	80	160	200	18	8	14	35	180	215	14	19	50	160	228	55	108
MCRE 83-1	82	988	-	63	491	156	1133	140	180	320	100	115	150	190	198	80	160	200	18	8	14	35	180	215	14	19	50	160	228	55	108
MCRE 80-2	41	1277	-	63	739	156	1381	140	180	320	100	115	150	190	488	80	160	200	18	8	14	35	180	215	14	19	50	160	228	55	119
MCRE 80-4	82	1238	-	63	741	156	1383	140	180	320	100	115	150	190	448	80	160	200	18	8	14	35	180	215	14	19	50	160	228	55	-
MCRE 80-4	41	1799	-	63	1261	156	1903	140	180	320	100	115	150	190	1010	80	160	200	18	8	14	35	180	215	14	19	50	160	228	55	-
MCRE 90-L	82	1760	-	63	1263	156	1905	140	180	320	100	115	150	190	970	80	160	200	18	8	14	35	180	215	14	19	50	160	228	55	-
MCRE 90-L	41	1347	-	63	809	156	1451	140	180	320	100	115	150	190	558	80	160	200	18	8	14	35	180	215	14	19	50	160	228	55	-
MCRE 100-1	52,5	1295,5	55	51	626	242	1454	160	200	360	185	145	190	240	290	100	180	220	18	8	18	42	230	265	16	18	60	185	195	42	155
MCRE 103-1	52,5	1601,5	55	51	932	242	1760	160	200	360	185	145	190	240	596	100	180	220	18	8	18	42	230	265	16	18	60	185	195	42	181
MCRE 100-2	52,5	2491,5	55	51	1809	255	2650	160	200	360	185	145	190	240	1225	100	180	220	18	8	18	42	230	265	16	18	60	185	195	42	-
MCRE 100-4N	52,5	1645,5	55	51	976	242	1804	160	200	360	185	145	190	240	640	100	180	220	18	8	18	42	230	265	16	18	60	185	195	42	-
MCRE 110-L	52,5	1335,5	55	51	666	242	1494	160	200	360	185	145	190	240	330	100	180	220	18	8	18	42	230	265	16	18	60	185	195	42	-
MCRE 115-1	52,5	1685,5	55	51	1016	242	1844	160	200	360	185	145	190	240	680	100	180	220	18	8	18	42	230	265	16	18	60	185	195	42	-
MCRE 115-2	52,5	1685,5	55	51	1016	242	1844	160	200	360	185	145	190	240	680	100	180	220	18	8	18	42	230	265	16	18	60	185	195	42	-
MCRE 125-1	46,5	1659,5	67	50	807	260	1823	180	200	380	215	170	230	280	387,5	125	210	250	18	8	18	55	230	265	18	18	65	210	222	43	219
MCRE 125-2	55	2059,5	67	50	815,5	260	1831,5	180	200	380	215	170	230	280	787,5	125	210	250	18	8	18	55	230	265	18	18	65	210	222	43	259
MCRE 130-L	46,5	1973,5	67	50	1207	260	2223	180	200	380	215	170	230	280	701,5	125	210	250	18	8	18	55	230	265	18	18	65	210	222	43	-
MCRE 130-L	55	1973,5	67	50	1121	260	2137	180	200	380	215	170	230	280	701,5	125	210	250	18	8	18	55	230	265	18	18	65	210	222	43	-
MCRE 140-L	46,5	2059,5	67	50	1207	260	2223	180	200	380	215	170	230	280	787,5	125	210	250	18	8	18	55	230	265	18	18	65	210	222	43	259
MCRE 140-L	55	2059,5	67	50	1207	260	2223	180	200	380	215	170	230	280	787,5	125	210	250	18	8	18	55	230	265	18	18	65	210	222	43	259
MCRE 150-1S	66	1881	70	50	1025	282	2067	200	250	450	-	200	200	250	509	150	240	285	22	8	22	55	230	265	16	22	90	262	266	75	-
MCRE 150-2	66	2381	70	50	1525	282	2567	200	250	450	-	200	200	250	1009	150	240	285	22	8	22	55	230	265	16	22	90	262	266	75	-
MCRE 150-2	66	2381	70	50	1525	282	2567	200	250	450	-	200	200	250	1009	150	240	285	22	8	22	55	230	265	16	22	90	262	266	75	-
MCRE 151-1,5	56	2232	70	50	1376	282	2408	200	250	450	-	200	200	250	854	200	295	340	22	12	22	55	230	265	16	22	90	262	266	75	-

OVERALL DIMENSIONS

MCRN

HOPPER, PRE-FEEDING SCREW AND VANE CRUSHER

TYPE	A	A1	P1	P2	Q1	Q2	Q3	R1	no. holes
MCRN 50-1	365	443	102,5	85	32,5	12,5	16,5	13	16
MCRN 50-2	365	443	102,5	85	32,5	12,5	16,5	13	16
MCRN 55-4	365	443	102,5	85	32,5	12,5	16,5	13	16
MCRN 60-L	365	443	102,5	85	32,5	12,5	16,5	13	16
MCRN 65-1	426	565	105	130	42,5	18	20	13	16
MCRN 65-2	426	565	105	130	42,5	18	20	13	16
MCRN 65-4	426	565	105	130	42,5	18	20	13	16
MCRN 70-L	426	565	105	130	42,5	18	20	13	16
MCRN 80-1	486	580	110	113	43	17	15	13	18
MCRN 80-2	486	580	110	113	43	17	15	13	18
MCRN 80-4	486	580	110	113	43	17	15	13	18
MCRN 90-L	486	580	110	113	43	17	15	13	18
MCRN 100-1	586	564	106	110	43	18	16	13	20
MCRN 103-1	586	564	106	110	43	18	16	13	20
MCRN 100-2	586	564	106	110	43	18	16	13	20

TYPE	A	A1	P1	P2	Q1	Q2	Q3	R1	no. holes
MCRN 100-4N	586	564	106	110	43	18	16	13	20
MCRN 110-L	586	564	106	110	43	18	16	13	20
MCRN 115-1	586	564	106	110	43	18	16	13	20
MCRN 115-2	586	564	106	110	43	18	16	13	20
MCRN 125-1	756	642	120	102	53	21	21	16	24
MCRN 125-2	756	642	120	102	53	21	21	16	24
MCRN 125-4	756	642	120	102	53	21	21	16	24
MCRN 130-L	756	642	120	102	53	21	21	16	24
MCRN 140-L	756	642	120	102	53	21	21	16	24
MCRN 150-1S	760	782	92	102	55	23	23	18	30
MCRN 150-2	760	782	92	102	55	23	23	18	30
MCRN 151-1,5	760	782	92	102	55	23	23	18	30
MCRN 160-L	760	782	92	102	55	23	23	18	30
MCRN 200-2	930	960	100	109	65	29	30	20	34
MCRN 200-L	930	960	100	109	65	29	30	20	34

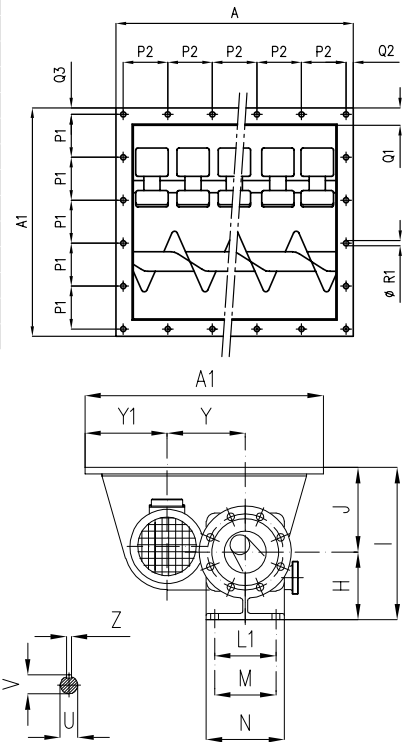

(*) The first parameter refers to a pump with outlet with EN 1092-1 PN16 flange; the second parameter refers to a pump with outlet with DIN 11851 male threaded connection.

Dimensions not binding

TYPE	(*) B	(*) C	D	E	(*) F	G	(*) K	H	J	I	L	L1	M	N	(*) O	(*) DN	P	Q	R	no. holes	S	T	U	V	Z	(*) X	Y	Y1	W	Weight Kg
MCRN 50-1	71	718	152	81	353,5	303,5	1022	100	160	260	68	85	85	110	102	50	-	-	-	-	12	50	25	28	8	35	139	166	27	-
MCRN 50-2	71	868	152	81	503,5	303,5	1172	100	160	260	68	85	85	110	252	50	125	165	18	4	12	50	25	28	8	35	139	166	27	-
MCRN 55-4	71	1174	152	81	809,5	303,5	1478	100	160	260	68	85	85	110	558	50	125	165	18	4	12	50	25	28	8	35	139	166	27	-
MCRN 60-L	71	884	152	81	519,5	303,5	1188	100	160	260	68	85	85	110	268	50	125	165	18	4	12	50	25	28	8	35	139	166	27	-
MCRN 65-1	71	863	204	102	436	378	1240	125	165	290	88	108	108	138	152	65	-	-	-	-	14	62	28	31	8	35	160	212,5	25	93
MCRN 65-2	44	1093	204	102	639	378	1443	125	165	290	88	108	108	138	382	65	145	185	18	4	14	62	28	31	8	45	160	212,5	25	100
MCRN 65-4	44	1503	204	102	1049	378	1853	125	165	290	88	108	108	138	792	65	145	185	18	4	14	62	28	31	8	45	160	212,5	25	100
MCRN 70-L	44	1093	204	102	639	378	1443	125	165	290	88	108	108	138	382	65	145	185	18	4	14	62	28	31	8	45	160	212,5	25	100
MCRN 80-1	41	1004	222	124	489	416	1391	140	180	320	100	115	115	155	238	80	160	200	18	8	14	75	35	38	10	50	160	228	34	116
MCRN 83-1	41	965	222	124	491	416	1393	140	180	320	100	115	115	155	198	80	160	200	18	8	14	75	35	38	10	39	160	228	34	116
MCRN 80-2	41	1254	222	124	739	416	1641	140	180	320	100	115	115	155	488	80	160	200	18	8	14	75	35	38	10	50	160	228	34	127
MCRN 80-4	41	1776	222	124	1261	416	2163	140	180	320	100	115	115	155	1010	80	160	200	18	8	14	75	35	38	10	50	160	228	34	-
MCRN 90-L	41	1324	222	124	809	416	1711	140	180	320	100	115	115	155	558	80	160	200	18	8	14	75	35	38	10	50	160	228	34	-
MCRN 100-1	52,5	1289,5	274	141	626	545	1757	160	200	360	185	145	145	185	290	100	180	220	18	8	18	90	42	45	12	60	185	195	35	175
MCRN 103-1	52,5	1595,5	274	141	932	545	2063	160	200	360	185	145	145	185	596	100	180	220	18	8	18	90	42	45	12	60	185	195	35	201
MCRN 100-4N	52,5	2490,5	274	141	1827	545	2958	160	200	360	185	145	145	185	1491	100	180	220	18	8	18	90	42	45	12	60	185	195	35	-
MCRN 110-L	52,5	1639,5	274	141	976	545	2107	160	200	360	185	145	145	185	640	100	180	220	18	8	18	90	42	45	12	60	185	195	35	-
MCRN 115-1	52,5	1329,5	274	141	666	545	1797	160	200	360	185	145	145	185	330	100	180	220	18	8	18	90	42	45	12	60	185	195	35	-
MCRN 115-2	52,5	1679,5	274	141	1016	545	2147	160	200	360	185	145	145	185	680	100	180	220	18	8	18	90	42	45	12	60	185	195	35	-
MCRN 125-1	46,5	1659,5	318	167	807	627,5	2190,5	180	200	380	215	170	170	215	387,5	125	210	250	18	8	18	110	55	59	16	65	210	222	40	244
MCRN 125-2	46,5	2059,5	318	167	1207	627,5	2590,5	180	200	380	215	170	170	215	787,5	125	210	250	18	8	18	110	55	59	16	65	210	222	40	284
MCRN 125-4	46,5	2870,5	318	167	2018	627,5	3401,5	180	200	380	215	170	170	215	1598,5	125	210	250	18	8	18	110	55	59	16	65	210	222	40	-
MCRN 130-L	46,5	1973,5	318	167	1121	627,5	2504,5	180	200	380	215	170	170	215	701,5	125	210	250	18	8	18	110	55	59	16	65	210	222	40	-
MCRN 140-L	46,5	2059,5	318	167	1207	627,5	2590,5	180	200	380	215	170	170	215	787,5	125	210	250	18	8	18	110	55	59	16	65	210	222	40	284
MCRN 150-1S	66	1894	298	177	1025	650	2435	200	250	450	-	200	200	250	509	150	240	285	22	8	22	110	55	59	16	90	262	266	50	366
MCRN 150-2	66	2394	298	177	1525	650	2935	200	250	450	-	200	200	250	1009	150	240	285	22	8	22	110	55	59	16	90	262	266	50	-
MCRN 151-1,5	56	2245	298	177	1376	650	2776	200	250	450	-	200	200	250	854	200	295	340	22	12	22	110	55	59	16	90	262	266	50	-
MCRN 160-L	66	2387	298	177	1518	650	2928	200	250	450	-	200	200	250	1002	150	240	285	22	8	22	110	55	59	16	90	262	266	50	-
MCRN 200-2	246	2814	260	216	1982	624	3535	230	300	530	-	190	240	290	1224	200	295	340	22	12	26	130	65	69	18	87	310	350	60	810
MCRN 200-L	246	2814	260	216	1982	624	3535	230	300	530	-	190	240	290	1224	200	295	340	22	12	26	130	65	69	18	87	310	350	60	810

UNDER CONSTRUCTION

OVERALL DIMENSIONS

MC2CE 65/80
MC2CRE

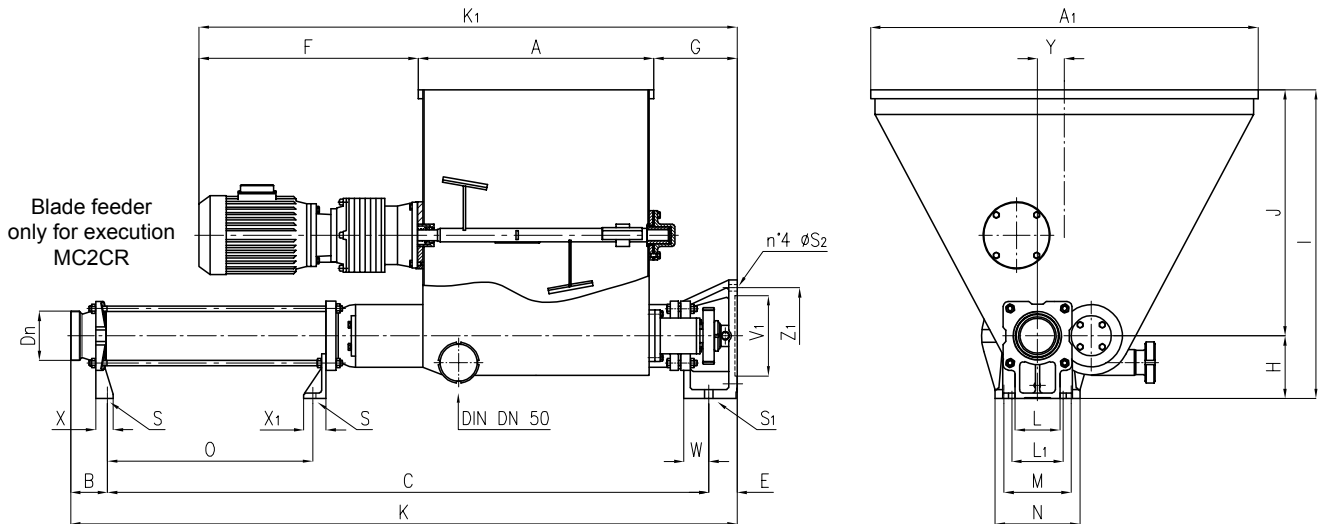

Dimensions not binding

TYPE	A	A1	B	C	D	E	K	K1	F	G	H	J	I	L	L1	M	N	O	DN	S	S1	S2	V1	Z1	X	X1	Y	W
MC2CE 65-1	466	765	71	986	-	59	1116	1140	490	184	125	490	615	88	108	140	180	152	65	14	19	14	180	215	35	45	50	52
MC2CE 65-2	466	765	71	1186	-	59	1316	1140	490	184	125	490	615	88	108	140	180	352	65	14	19	14	180	215	35	45	50	52
MC2CE 80-2	526	866	82	1344	-	63	1489	1202	490	186	140	550	690	100	115	150	190	448	80	14	19	14	180	215	39	50	60	56

MC2CE 100/125
MC2CRE

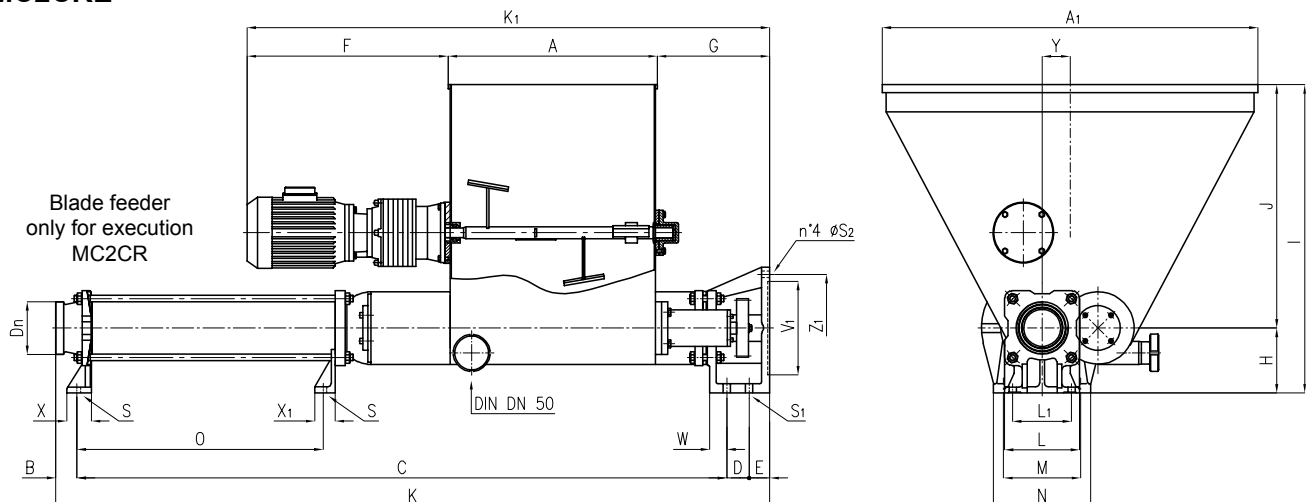

Dimensions not binding

TYPE	A	A1	B	C	D	E	K	K1	F	G	H	J	I	L	L1	M	N	O	DN	S	S1	S2	V1	Z1	X	X1	Y	W
MC2CE 100-1	526	926	52	1290	55	51	1448	1288	490	272	160	600	760	185	145	190	240	291	100	18	19	16	230	265	60	50	69	42
MC2CE 100-2	526	926	52	1596	55	51	1754	1288	490	272	160	600	760	185	145	190	240	597	100	18	19	16	230	265	60	50	69	42
MC2CE 125-1	676	898	55	1665	67	50	1782	1466	490	300	183	500	683	215	170	230	280	462	100	18	16	18	230	265	65	65	86	43
MC2CE 125-2	676	898	55	2065	67	50	2182	1466	490	300	183	500	683	215	170	230	280	863	100	18	16	18	230	265	65	65	86	43

OVERALL DIMENSIONS FOR HOPPER LIDS

TYPE	DN	A	A1	P1	P2	Q1	Q2	Q3	R1	no. holes	
MCE MCN	40-1 40-2	40	300	210	70	63,3	27,5	10	10	9	14
MCE MCN	50-1 50-2 55-4 60-L	50	365	250	69	57,5	32,5	10	10	11	18
MCE MCN	65-1 63-1 65-2 65-4 70-L	65	426	260	130	116	43	14	18	13	10
MCE MCN	80-1 83-1 80-2 80-4 90-L	80	486	326	113	146	43	17	17	13	12
MCE MCN	100-1 103-1 100-2 100-4N 110-L 115-1 115-2	100	586	340	110	103	43	15	18	13	16
MCE MCN	125-1 125-2 125-4 130-L 140-L	100 125	756	420	102	96	53	18	21	18	22
MCE MCN	150-1S 150-2 151-1,5 160-L	150	760	510	102	92	53	24	23	18	24
MCN	200-2 200-L	200	930	620	109	94	65	28	29	20	28

TYPE	DN	A	A1	P1	P2	Q1	Q2	Q3	R1	no. holes	
MCRE MCRN	50-1 50-2 55-4 60-L	50	365	443	102,5	85	32,5	12,5	16,5	13	16
MCRE MCRN	65-1 63-1 65-2 65-4 70-L	65	426	565	105	130	42,5	18	20	13	16
MCRE MCRN	80-1 83-1 80-2 80-4 90-L	80	486	580	110	113	43	17	15	13	18
MCRE MCRN	100-1 103-1 100-2 110-L 115-1 115-2	100	586	564	106	110	43	18	16	13	20
MCRE MCRN	125-1 125-2 130-L 140-L	100 125	756	642	120	102	53	21	21	16	24
MCRE MCRN	150-1S 150-2 151-1,5 160-L	150	760	782	92	102	55	23	23	18	30
MCRN	200-2 200-L	200	930	960	100	109	65	29	30	20	34

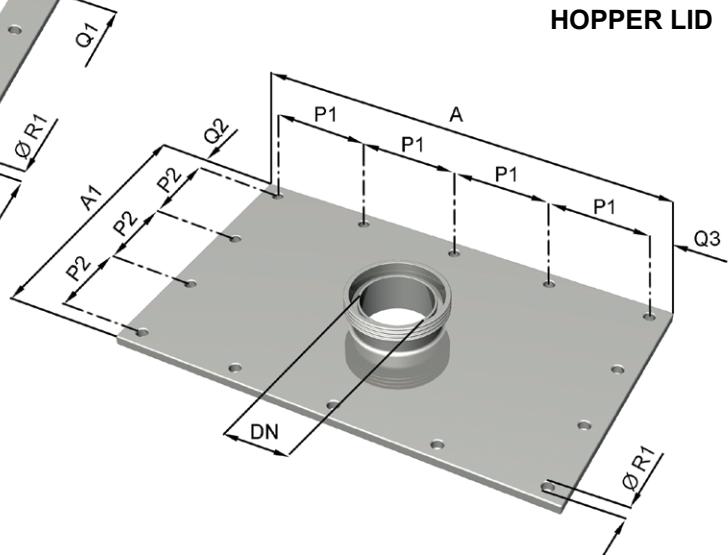
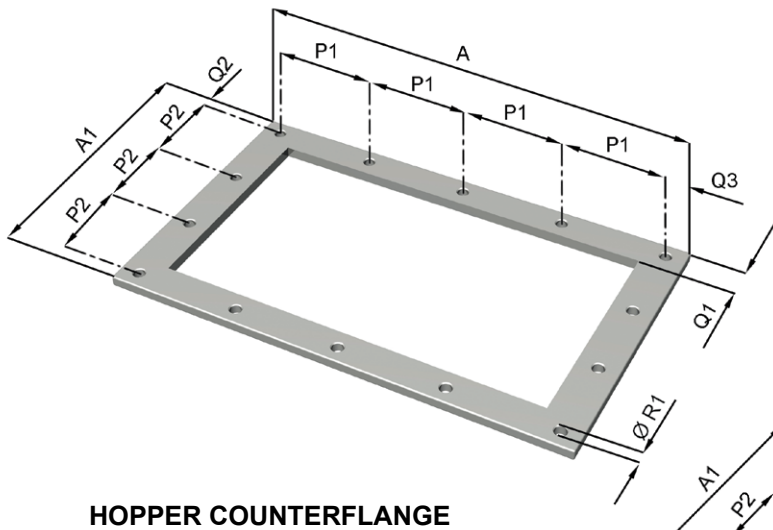

Dimensions not binding

Type	DN	D	E	F	F'	G	H	H'	J	K	L	N	S	Z
MAV 40-1	40	-	-	1103	-	126	70	-	79	1229	-	-	-	265
MAV 50-1	50	92	-	1086	-	198	100	-	86	1284	110	150	17	476
MAV 50-2	50	92	-	1236	-	198	100	-	86	1434	110	150	17	476
MAV 60-L	50	92	-	1255	1273	198	100	220	86	1453	110	150	17	494
MAV 65-1	65	111	-	1103	1142	226	130	220	113	1329	140	180	19	494
MAV 65-2	65	111	-	1303	1342	226	130	220	113	1529	140	180	19	494
MAV 70-L	65	111	-	1303	1342	226	130	220	113	1529	140	180	19	576
MAV 80-1	80	115	5	1104	1124	221	150	275	119,5	1325	150	190	19	726
MAV 80-2	80	115	5	1354	1374	221	150	255	119,5	1575	150	190	19	726
MAV 90-L	80	115	5	1243	1251	221	155	275	119,5	1644	150	190	19	726

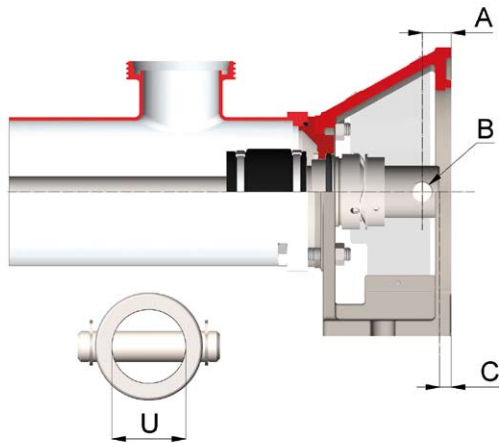

Type	A	B H7	C	U H7
MAV 40-1	20	8	=	19
MAV 50-1	25	10	10	24
MAV 50-2	25	10	10	24
MAV 60-L	25	10	10	24
MAV 65-1	25	14	10	32
MAV 65-2	25	14	10	32
MAV 70-L	25	14	10	32
MAV 80-1	26	16	10	35
MAV 80-2	26	16	10	35
MAV 90-L	26	16	10	35

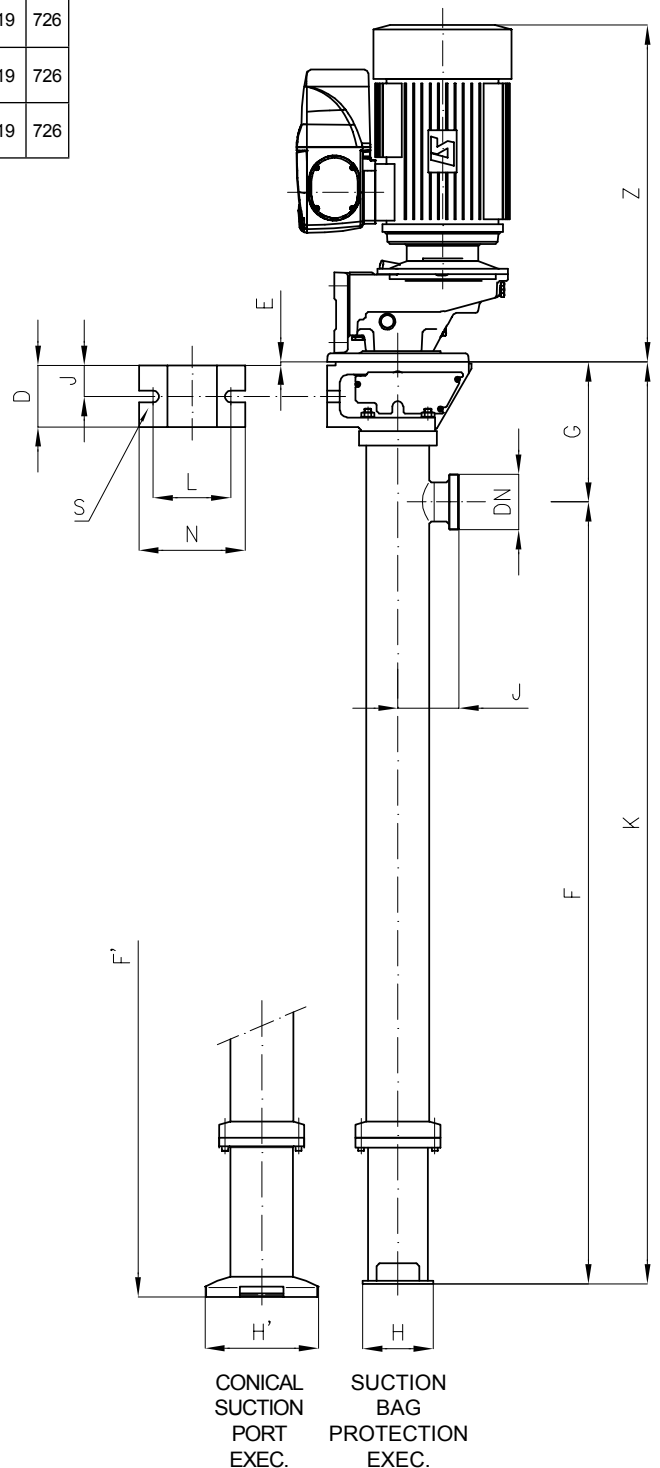

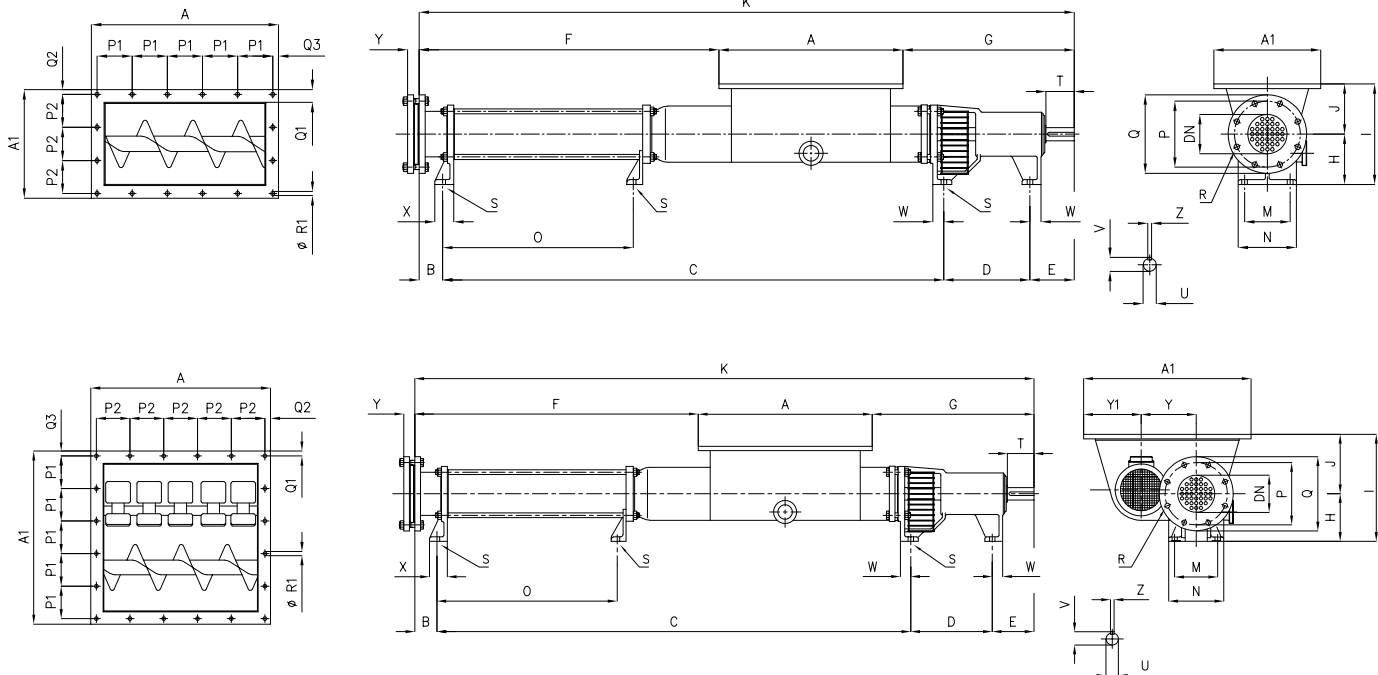

Dimensions not binding

Type	DIN DN	B	C	D	E	F	G	K	H	J	I	M	N	O	DN	P	Q	R	n° holes	S	T	U	V	Z	X	Y	Y1	W
MCN 80-2	80	51,5	1215	222	124	750	416	1652	140	140	280	115	155	458	100	180	220	18	8	14	75	35	38	10	39	35	-	34
MCRN 80-2	80	51,5	1215	222	124	750	416	1652	140	180	320	115	155	458	100	180	220	18	8	14	75	35	38	10	39	160	228	34
MCN 80-4	80	51,5	1737	222	124	1272	416	2174	140	140	280	115	155	980	100	180	220	18	8	14	75	35	38	10	39	35	-	34
MCRN 80-4	80	51,5	1737	222	124	1272	416	2174	140	180	320	115	155	980	100	180	220	18	8	14	75	35	38	10	39	160	228	34
MCN 100-2	100	75	1595,5	274	141	954,5	545	2085,5	160	160	320	145	185	606	125	210	250	18	8	18	90	42	45	12	60	37	-	35
MCRN 100-2	100	75	1595,5	274	141	954,5	545	2085,5	160	200	360	145	185	606	125	210	250	18	8	18	90	42	45	12	60	185	195	35
MCN 100-4N	100	75	2490,5	274	141	1849,5	545	2980,5	160	160	320	145	185	1501	125	210	250	18	8	18	90	42	45	12	60	37	-	35
MCRN 100-4N	100	75	2490,5	274	141	1849,5	545	2980,5	160	200	360	145	185	1501	125	210	250	18	8	18	90	42	45	12	60	185	195	35
MCN 125-2	100	81	2059,5	318	167	1243,5	627,5	2627	180	180	360	170	215	797,5	150	240	285	22	8	18	110	55	59	16	65	37	-	40
MCRN 125-2	100	81	2059,5	318	167	1243,5	627,5	2627	180	200	380	170	215	797,5	150	240	285	22	8	18	110	55	59	16	65	210	222	40
MCN 125-4	100	81	2870,5	318	167	2056	627,5	3439,5	180	180	360	170	215	1608,5	150	240	285	22	8	18	110	55	59	16	65	37	-	40
MCRN 125-4	100	81	2870,5	318	167	2056	627,5	3439,5	180	200	380	170	215	1608,5	150	240	285	22	8	18	110	55	59	16	65	210	222	40
MCN 150-1S	150	114	1894	298	177	1073	650	2480,5	200	200	400	200	250	519	200	295	340	22	8	22	110	55	59	16	90	42	-	50
MCRN 150-1S	150	114	1894	298	177	1073	650	2480,5	200	250	450	200	250	519	200	295	340	22	8	22	110	55	59	16	90	262	266	50
MCN 150-2	150	114	2394	298	177	1573	650	2980,5	200	200	400	200	250	1019	200	295	340	22	8	22	110	55	59	16	90	42	-	50
MCRN 150-2	150	114	2394	298	177	1573	650	2980,5	200	250	450	200	250	1019	200	295	340	22	8	22	110	55	59	16	90	262	266	50

Type	A	A1	P1	P2	Q1	Q2	Q3	R1	n° holes
MCN 80-2	486	326	113	146	43	17	17	13	12
MCRN 80-2	486	580	110	113	43	17	15	13	18
MCN 80-4	486	326	113	146	43	17	17	13	12
MCRN 80-4	486	580	110	113	43	17	15	13	18
MCN 100-2	586	340	110	103	43	15	18	13	16
MCRN 100-2	586	564	106	110	43	18	16	13	20
MCN 100-4N	586	340	110	103	43	15	18	13	16
MCRN 100-4N	586	564	106	110	43	18	16	13	20
MCN 125-2	756	420	102	96	53	18	21	18	22
MCRN 125-2	756	642	120	102	53	21	21	16	24
MCN 125-4	756	420	102	96	53	18	21	18	22
MCRN 125-4	756	642	120	102	53	21	21	16	24
MCN 150-1S	760	510	102	92	53	25	23	18	24
MCRN 150-1S	760	782	92	102	55	23	23	18	30
MCN 150-2	760	510	102	92	53	25	23	18	24
MCRN 150-2	760	782	92	102	55	23	23	18	30

DIN DISCHARGE PORT EXEC.

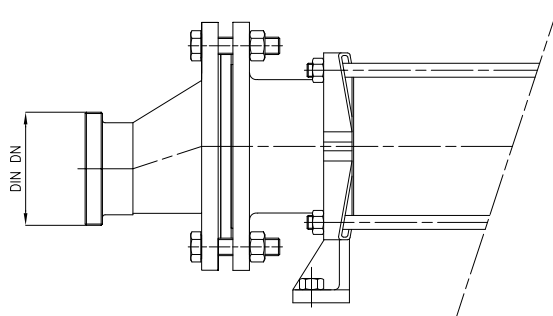

CURVE CARATTERISTICHE

PERFORMANCE CURVES

Serie MONOVITE

POSITIVE-DISPLACEMENT SCREW Series

POMPA TIPO Pump type		M 25 - 1				Raccordi femmina DIN 11851 Connection male DIN 11851	
Rotore Rotor fino a 70°C up to 158°F	Rotore ridotto Reduced rotor 70°C - 140°C 158°F - 212°F	Potenza minima installata Minimum installed power	Spinta assiale massima Maximum axial thrust	Passaggio sferico Sphere size	Portata teorica a giro Theoretical revolutional delivery	Bocca aspir. Suction port	DN 25
15,2 mm Eccentricità eccentricity	14,9 mm Eccentricità eccentricity	0,37 kW	210 N Coppia di spunto Starting torque	12 mm	0,015 l	Bocca mand. Discharge port	DN 25
3 mm	3 mm		2,8 Nm	1 mm			

Dimensione massima prodotto solido
Maximum dimension of the solid product

Dimensione massima prodotto solido
Maximum dimension of the solid product

CARATTERISTICHE DI FUNZIONAMENTO CON ACQUA PULITA A 20°C - PESO SPECIFICO 1 (kg/dm³) - VISCOSITÀ 1 (cps)
Curves show performance with clear water at 68°F - Specific gravity 1 (kg/dm³) - Viscosity 1 (cps)

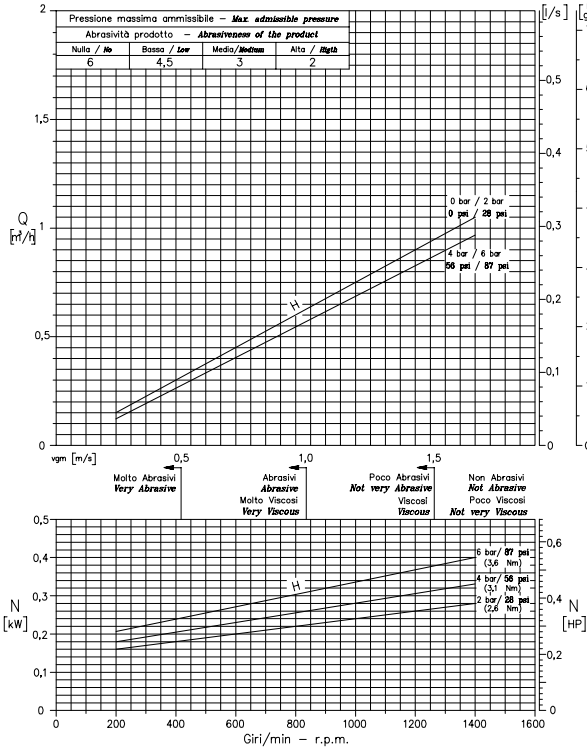

POMPA TIPO Pump type		M 25 - 2				Raccordi femmina DIN 11851 Connection male DIN 11851	
Rotore Rotor fino a 70°C up to 158°F	Rotore ridotto Reduced rotor 70°C - 140°C 158°F - 212°F	Potenza minima installata Minimum installed power	Spinta assiale massima Maximum axial thrust	Passaggio sferico Sphere size	Portata teorica a giro Theoretical revolutional delivery	Bocca aspir. Suction port	DN 25
15,2 mm Eccentricità eccentricity	14,9 mm Eccentricità eccentricity	0,37 kW	425 N Coppia di spunto Starting torque	12 mm	0,015 l	Bocca mand. Discharge port	DN 25
3 mm	3 mm		5,5 Nm	1 mm			

Dimensione massima prodotto solido
Maximum dimension of the solid product

Dimensione massima prodotto solido
Maximum dimension of the solid product

CARATTERISTICHE DI FUNZIONAMENTO CON ACQUA PULITA A 20°C - PESO SPECIFICO 1 (kg/dm³) - VISCOSITÀ 1 (cps)
Curves show performance with clear water at 68°F - Specific gravity 1 (kg/dm³) - Viscosity 1 (cps)

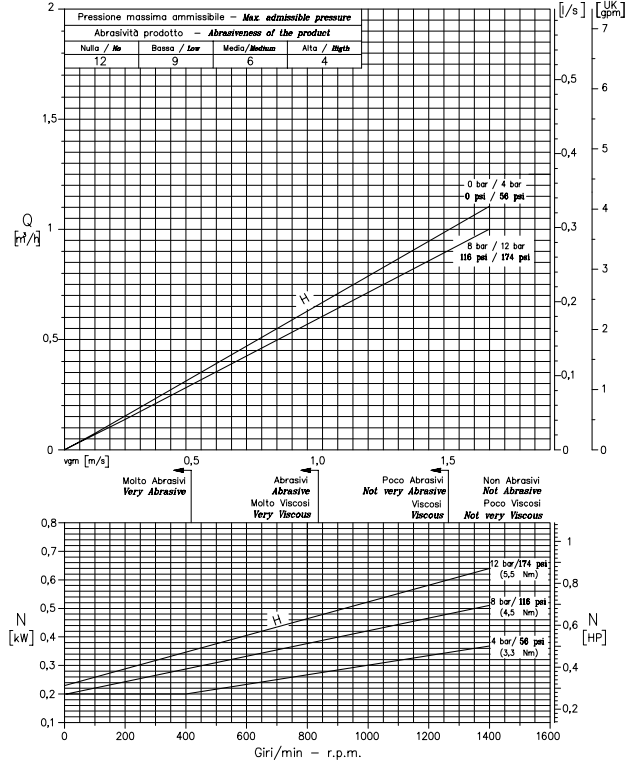

POMPA TIPO Pump type		M 40 - 1				Raccordi femmina DIN 11851 Connection male DIN 11851	
Rotore Rotor fino a 70°C up to 158°F	Rotore ridotto Reduced rotor 70°C - 140°C 158°F - 212°F	Potenza minima installata Minimum installed power	Spinta assiale massima Maximum axial thrust	Passaggio sferico Sphere size	Portata teorica a giro Theoretical revolutional delivery	Bocca aspir. Suction port	DN 40
20,3 mm Eccentricità eccentricity	20,15 mm Eccentricità eccentricity	0,55 kW	375 N Coppia di spunto Starting torque	15,4 mm	0,033 l	Bocca mand. Discharge port	DN 40
4 mm	4 mm		4 Nm	1,2 mm			

Dimensione massima prodotto solido
Maximum dimension of the solid product

Dimensione massima prodotto solido
Maximum dimension of the solid product

CARATTERISTICHE DI FUNZIONAMENTO CON ACQUA PULITA A 20°C - PESO SPECIFICO 1 (kg/dm³) - VISCOSITÀ 1 (cps)
Curves show performance with clear water at 68°F - Specific gravity 1 (kg/dm³) - Viscosity 1 (cps)

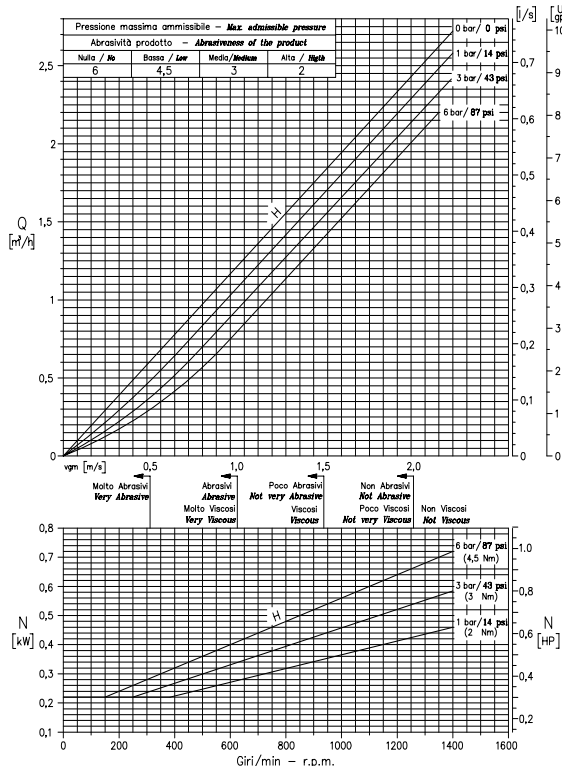

POMPA TIPO Pump type		M 40 - 2				Raccordi femmina DIN 11851 Connection male DIN 11851	
Rotore Rotor fino a 70°C up to 158°F	Rotore ridotto Reduced rotor 70°C - 140°C 158°F - 212°F	Potenza minima installata Minimum installed power	Spinta assiale massima Maximum axial thrust	Passaggio sferico Sphere size	Portata teorica a giro Theoretical revolutional delivery	Bocca aspir. Suction port	DN 40
20,45 mm Eccentricità eccentricity	20,3 mm Eccentricità eccentricity	0,55 kW	755 N Coppia di spunto Starting torque	15,25 mm	0,033 l	Bocca mand. Discharge port	DN 40
4 mm	4 mm		7,8 Nm	1,2 mm			

Dimensione massima prodotto solido
Maximum dimension of the solid product

Dimensione massima prodotto solido
Maximum dimension of the solid product

CARATTERISTICHE DI FUNZIONAMENTO CON ACQUA PULITA A 20°C - PESO SPECIFICO 1 (kg/dm³) - VISCOSITÀ 1 (cps)
Curves show performance with clear water at 68°F - Specific gravity 1 (kg/dm³) - Viscosity 1 (cps)

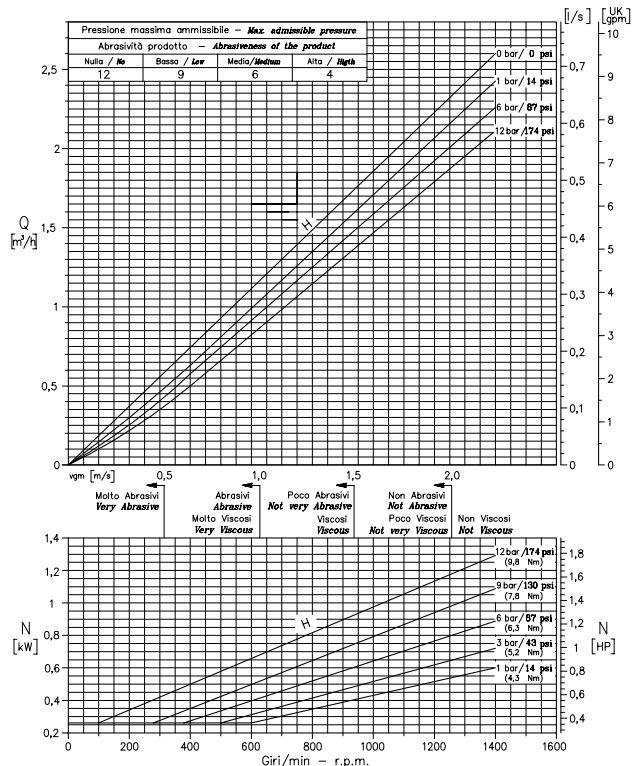

CURVE CARATTERISTICHE

PERFORMANCE CURVES

Serie MONOVITE

POSITIVE-DISPLACEMENT SCREW Series

POMPA TIPO Pump type		M 50 - 1				Raccordi femmina DIN 11851 Connection male DIN 11851	
Rotore fino a 70°C up to 158°F	Rotore ridotto fino a 70°C up to 158°F	Potenza minima installata	Spinta assiale massima	Passaggio sferico	Portata teorica a giro	Bocca aspir. DN 50 Suction port Bocca mand. DN 50 Discharge port	
30,6 mm	30,3 mm	855 N	24 mm	2,5 mm	0,11 l		
Eccentricità "h"	Eccentricità "h"	Coppia di spunto	Dimensione massima prodotto solido				
6 mm	6 mm	11,5 Nm	Maximum dimension of the solid product				

CARATTERISTICHE DI FUNZIONAMENTO CON ACQUA PULITA A 20°C - PESO SPECIFICO 1 (kg/dm³) - VISCOSITÀ 1 (cps)
Curves show performance with clear water at 68°F - Specific gravity 1 (kg/dm³) - Viscosity 1 (cps)

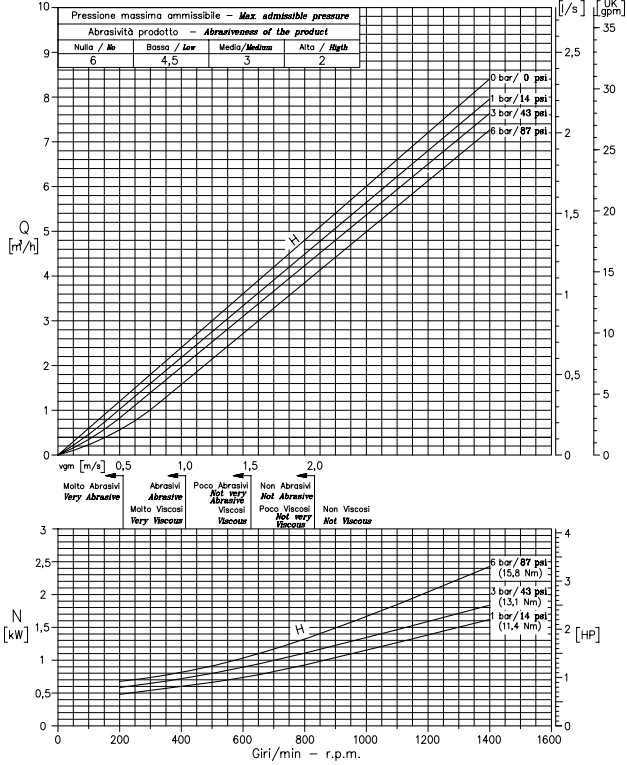

POMPA TIPO Pump type		M 50 - 1				BASSE VELOCITÀ LOW SPEED		Raccordi femmina DIN 11851 Connection male DIN 11851	
Rotore fino a 70°C up to 158°F	Rotore ridotto fino a 70°C up to 158°F	Potenza minima installata	Spinta assiale massima	Passaggio sferico	Portata teorica a giro	Bocca aspir. DN 50 Suction part Bocca mand. DN 50 Discharge port			
30,6 mm	30,3 mm	855 N	24 mm	2,5 mm	0,11 l				
Eccentricità "h"	Eccentricità "h"	Coppia di spunto	Dimensione massima prodotto solido						
6 mm	6 mm	11,5 Nm	Maximum dimension of the solid product						

CARATTERISTICHE DI FUNZIONAMENTO CON ACQUA PULITA A 20°C - PESO SPECIFICO 1 (kg/dm³) - VISCOSITÀ 1 (cps)
Curves show performance with clear water at 68°F - Specific gravity 1 (kg/dm³) - Viscosity 1 (cps)

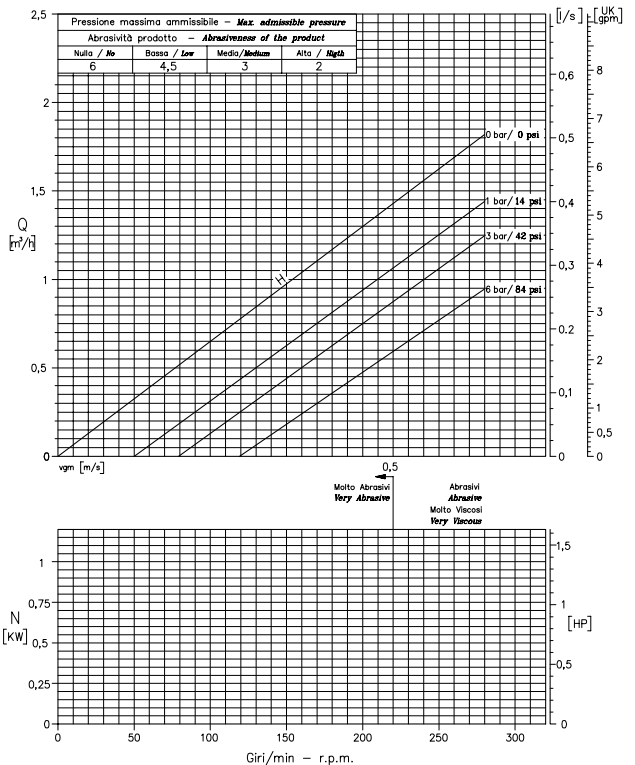

POMPA TIPO Pump type		M 50 - 2				Raccordi femmina DIN 11851 Connection male DIN 11851	
Rotore fino a 70°C up to 158°F	Rotore ridotto fino a 70°C up to 158°F	Potenza minima installata	Spinta assiale massima	Passaggio sferico	Portata teorica a giro	Bocca aspir. DN 50 Suction port Bocca mand. DN 50 Discharge port	
30,6 mm	30,3 mm	1710 N	24,6 mm	2,5 mm	0,11 l		
Eccentricità "h"	Eccentricità "h"	Coppia di spunto	Dimensione massima prodotto solido				
6 mm	6 mm	22,5 Nm	Maximum dimension of the solid product				

CARATTERISTICHE DI FUNZIONAMENTO CON ACQUA PULITA A 20°C - PESO SPECIFICO 1 (kg/dm³) - VISCOSITÀ 1 (cps)
Curves show performance with clear water at 68°F - Specific gravity 1 (kg/dm³) - Viscosity 1 (cps)

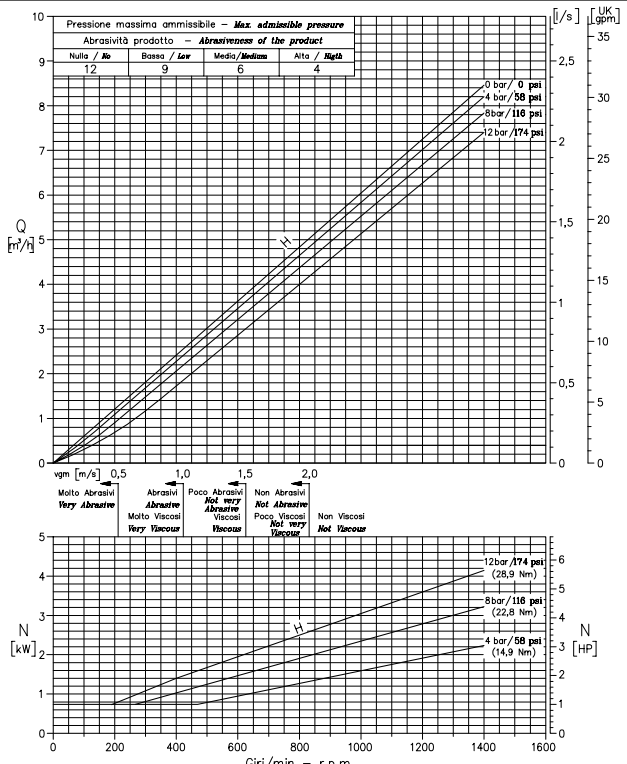

POMPA TIPO Pump type		M 55 - 4				Raccordi femmina DIN 11851 Connection male DIN 11851	
Rotore fino a 70°C up to 158°F	Rotore ridotto fino a 70°C up to 158°F	Potenza minima installata	Spinta assiale massima	Passaggio sferico	Portata teorica a giro	Bocca aspir. DN 50 Suction port Bocca mand. DN 50 Discharge port	
30 mm	29,5 mm	3325 N	23,7 mm	2 mm	0,11 l		
Eccentricità "h"	Eccentricità "h"	Coppia di spunto	Dimensione massima prodotto solido				
6 mm	6 mm	42 Nm	Maximum dimension of the solid product				

CARATTERISTICHE DI FUNZIONAMENTO CON ACQUA PULITA A 20°C - PESO SPECIFICO 1 (kg/dm³) - VISCOSITÀ 1 (cps)
Curves show performance with clear water at 68°F - Specific gravity 1 (kg/dm³) - Viscosity 1 (cps)

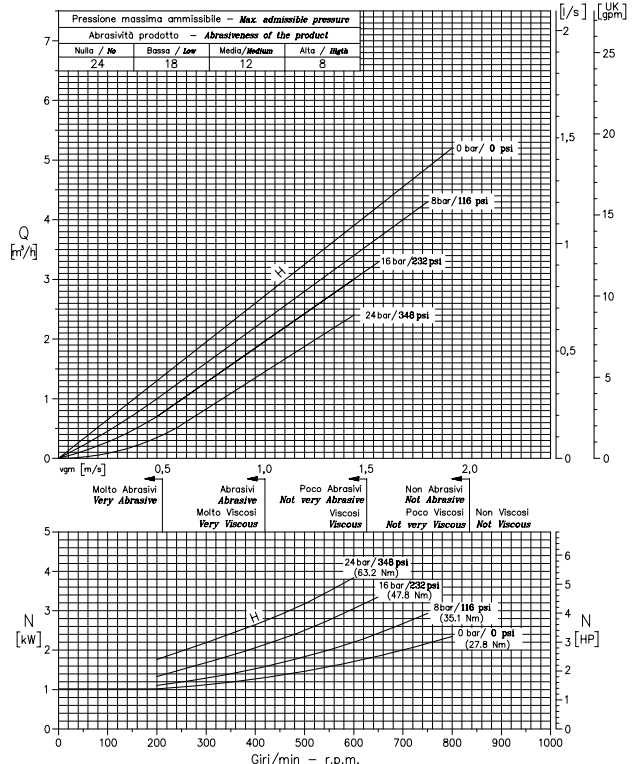

CURVE CARATTERISTICHE

PERFORMANCE CURVES

Serie MONOVITE

POSITIVE-DISPLACEMENT SCREW Series

POMPA TIPO Pump type		M 60 - L				Raccordi femmina DIN 11851 Connection male DIN 11851	
Rotore fino a 70°C up to 158°F	Rotore ridotto 70°C - 100°C 158°F - 212°F	Potenza minima installata Minimum installed power	Spinta assiale massima Maximum axial thrust	Passaggio sferico Sphere size	Portata teorica a giro Theoretical revolutional delivery	Bocca aspir. Suction port	Bocca mand. Discharge port
33,6 mm	33,3 mm	1,5 kW	965 N	23,2 mm	0,252 l	DN 50	DN 50
Eccentricità "h" Eccentricity	5,85 mm		Coppia di spunto Starting torque	Dimensione massima prodotta solido Maximum dimension of the solid product			
			20 Nm	2,5 mm			

CARATTERISTICHE DI FUNZIONAMENTO CON ACQUA PULITA A 20°C - PESO SPECIFICO 1 (kg/dm³) - VISCOSITÀ 1 (cps)
Curves show performance with clear water at 68°F - Specific gravity 1 (kg/dm³) - Viscosity 1 (cps)

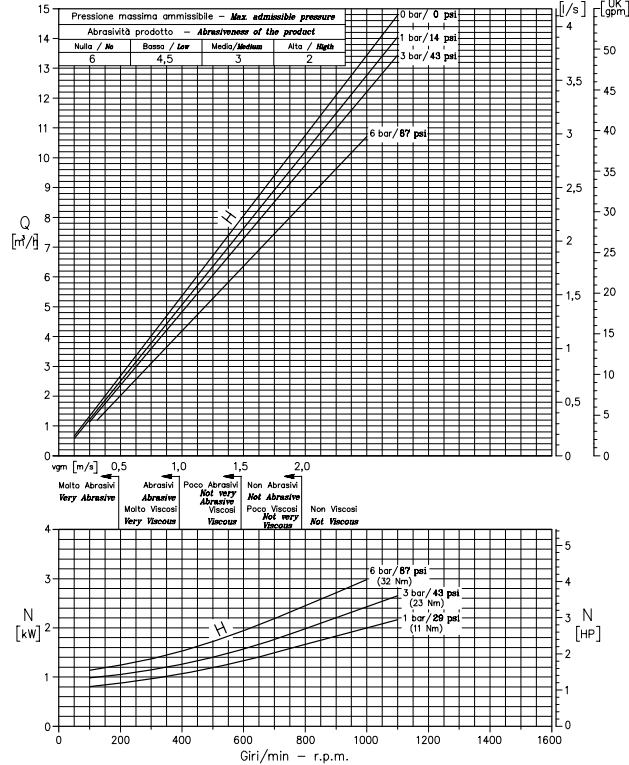

POMPA TIPO Pump type		M 65 - 1				Raccordi femmina DIN 11851 Connection male DIN 11851	
Rotore fino a 70°C up to 158°F	Rotore ridotto 70°C - 100°C 158°F - 212°F	Potenza minima installata Minimum installed power	Spinta assiale massima Maximum axial thrust	Passaggio sferico Sphere size	Portata teorica a giro Theoretical revolutional delivery	Bocca aspir. Suction port	Bocca mand. Discharge port
42,2 mm	41,8 mm	1,5 kW	1540 N	29,4 mm	0,253 l	DN 65	DN 65
Eccentricità "h" Eccentricity	7,5 mm		Coppia di spunto Starting torque	Dimensione massima prodotta solido Maximum dimension of the solid product			
			25 Nm	3,5 mm			

CARATTERISTICHE DI FUNZIONAMENTO CON ACQUA PULITA A 20°C - PESO SPECIFICO 1 (kg/dm³) - VISCOSITÀ 1 (cps)
Curves show performance with clear water at 68°F - Specific gravity 1 (kg/dm³) - Viscosity 1 (cps)

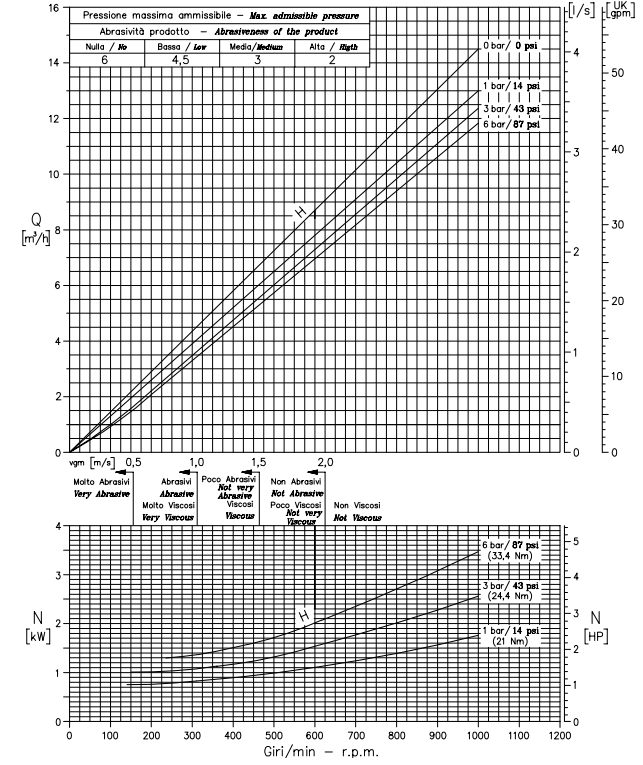

POMPA TIPO Pump type		M 65 - 2				Raccordi femmina DIN 11851 Connection male DIN 11851	
Rotore fino a 70°C up to 158°F	Rotore ridotto 70°C - 100°C 158°F - 212°F	Potenza minima installata Minimum installed power	Spinta assiale massima Maximum axial thrust	Passaggio sferico Sphere size	Portata teorica a giro Theoretical revolutional delivery	Bocca aspir. Suction port	Bocca mand. Discharge port
42,2 mm	41,8 mm	2,2 kW	3080 N	29,4 mm	0,253 l	DN 65	DN 65
Eccentricità "h" Eccentricity	7,5 mm		Coppia di spunto Starting torque	Dimensione massima prodotta solido Maximum dimension of the solid product			
			56 Nm	3,5 mm			

CARATTERISTICHE DI FUNZIONAMENTO CON ACQUA PULITA A 20°C - PESO SPECIFICO 1 (kg/dm³) - VISCOSITÀ 1 (cps)
Curves show performance with clear water at 68°F - Specific gravity 1 (kg/dm³) - Viscosity 1 (cps)

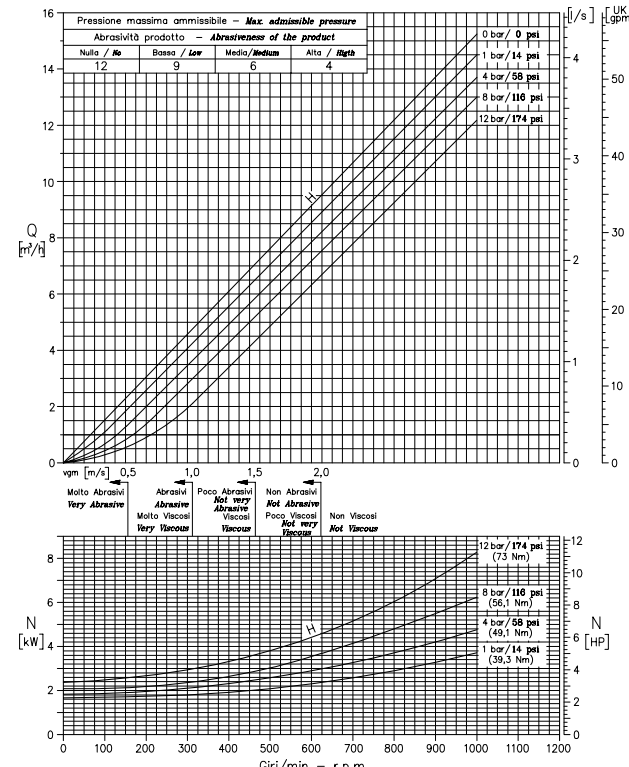

POMPA TIPO Pump type		M 65 - 2S				Raccordi femmina DIN 11851 Connection male DIN 11851	
Rotore fino a 70°C up to 158°F	Rotore ridotto 70°C - 100°C 158°F - 212°F	Potenza minima installata Minimum installed power	Spinta assiale massima Maximum axial thrust	Passaggio sferico Sphere size	Portata teorica a giro Theoretical revolutional delivery	Bocca aspir. Suction port	Bocca mand. Discharge port
42,8 mm	---	2,2 kW	5135 N	29,4 mm	0,257 l	DN 65	DN 65
Eccentricità "h" Eccentricity	---		Coppia di spunto Starting torque	Dimensione massima prodotta solido Maximum dimension of the solid product			
			79 Nm	3,5 mm			

CARATTERISTICHE DI FUNZIONAMENTO CON ACQUA PULITA A 20°C - PESO SPECIFICO 1 (kg/dm³) - VISCOSITÀ 1 (cps)
Curves show performance with clear water at 68°F - Specific gravity 1 (kg/dm³) - Viscosity 1 (cps)

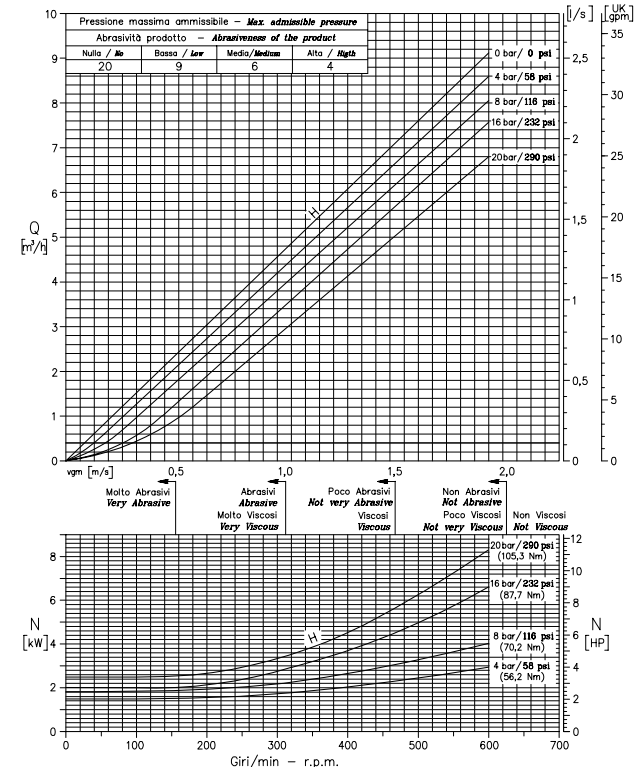

CURVE CARATTERISTICHE

PERFORMANCE CURVES

Serie MONOVITE

POSITIVE-DISPLACEMENT SCREW Series

POMPA TIPO Pump type		M 65 - 4				Raccordi femmina DIN 11851 Connection male DIN 11851	
Rotore fino a 70°C up to 158°F	Rotore ridotto 70°C - 100°C 158°F - 212°F	Potenza minima installata Minimum installed power	Spinta assiale massima installata Maximum axial thrust installed	Passaggio sferico Sphere size	Portata teorica a giro Theoretical revolutional delivery	Bocca aspir. Suction port DN 65	
42,5 mm Eccentricità "h" 7,4 mm	41,4 mm Eccentricità "h" 7,5 mm	2,2 kW	6185 N Coppia di spunto Starting torque 90 Nm	29,4 mm Dimensione massima prodotto solido Maximum dimension of the solid product 3 mm	0,253 l	Bocca mand. Discharge port DN 65	

CARATTERISTICHE DI FUNZIONAMENTO CON ACQUA PULITA A 20°C - PESO SPECIFICO 1 (kg/dm³) - VISCOSITÀ 1 (cps)
Curves show performance with clear water at 68°F - Specific gravity 1 (kg/dm³) - Viscosity 1 (cps)

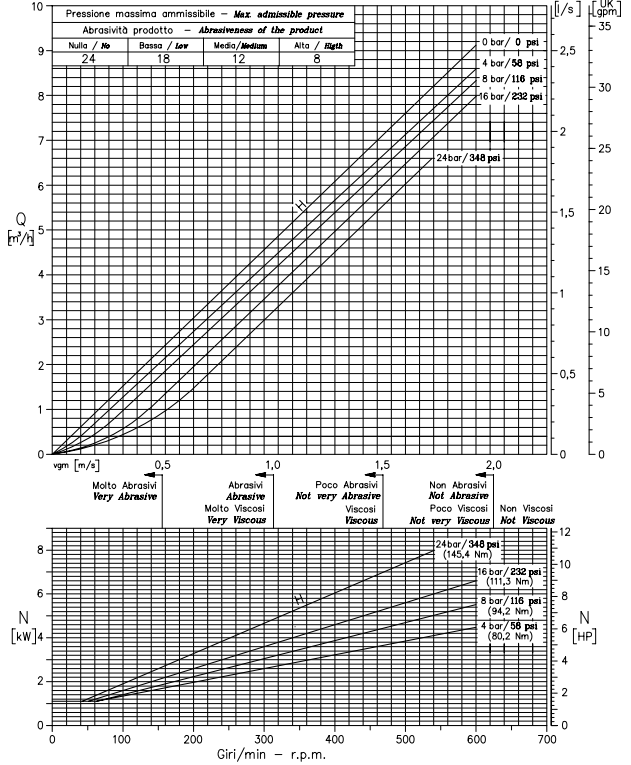

POMPA TIPO Pump type		M 63 - 1				Raccordi femmina DIN 11851 Connection male DIN 11851	
Rotore fino a 70°C up to 158°F	Rotore ridotto 70°C - 100°C 158°F - 212°F	Potenza minima installata Minimum installed power	Spinta assiale massima installata Maximum axial thrust installed	Passaggio sferico Sphere size	Portata teorica a giro Theoretical revolutional delivery	Bocca aspir. Suction port DN 65	
40,6 / 61,2 mm Eccentricità "h" 5,15 mm	40,4 / 61 mm Eccentricità "h" 5,15 mm	1,5 kW	1135 N Coppia di spunto Starting torque 40 Nm	15 mm Dimensione massima prodotto solido Maximum dimension of the solid product 1,2 mm	0,317 l	Bocca mand. Discharge port DN 65	

CARATTERISTICHE DI FUNZIONAMENTO CON ACQUA PULITA A 20°C - PESO SPECIFICO 1 (kg/dm³) - VISCOSITÀ 1 (cps)
Curves show performance with clear water at 68°F - Specific gravity 1 (kg/dm³) - Viscosity 1 (cps)

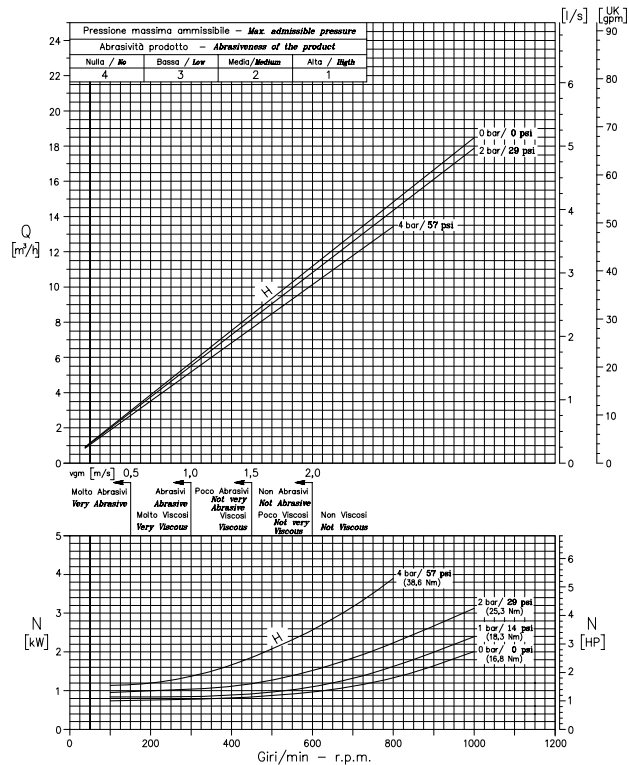

POMPA TIPO Pump type		M 70 - L				Raccordi femmina DIN 11851 Connection male DIN 11851	
Rotore fino a 70°C up to 158°F	Rotore ridotto 70°C - 100°C 158°F - 212°F	Potenza minima installata Minimum installed power	Spinta assiale massima installata Maximum axial thrust installed	Passaggio sferico Sphere size	Portata teorica a giro Theoretical revolutional delivery	Bocca aspir. Suction port DN 65	
43,3 mm Eccentricità "h" 7,25 mm	42,6 mm Eccentricità "h" 7,25 mm	1,84 kW	1575 N Coppia di spunto Starting torque 41 Nm	28,8 mm Dimensione massima prodotto solido Maximum dimension of the solid product 3 mm	0,5 l	Bocca mand. Discharge port DN 65	

CARATTERISTICHE DI FUNZIONAMENTO CON ACQUA PULITA A 20°C - PESO SPECIFICO 1 (kg/dm³) - VISCOSITÀ 1 (cps)
Curves show performance with clear water at 68°F - Specific gravity 1 (kg/dm³) - Viscosity 1 (cps)

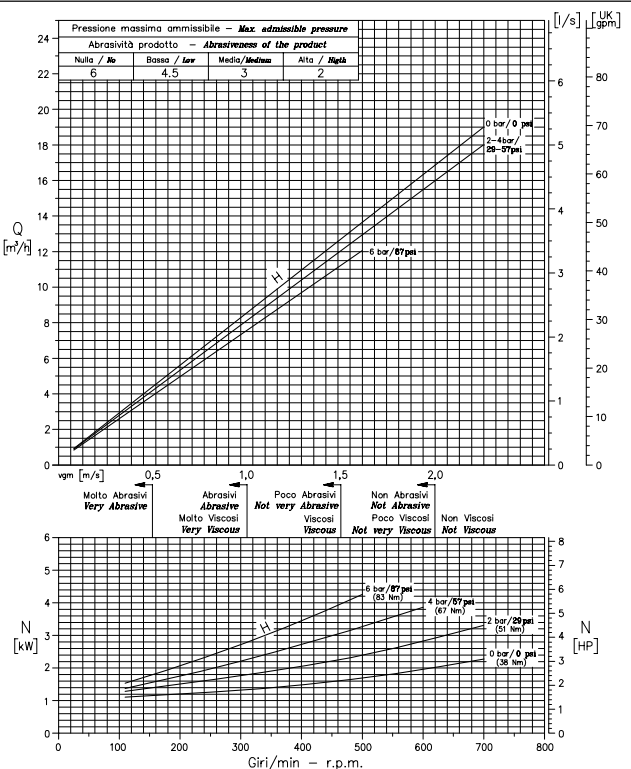

POMPA TIPO Pump type		M 80 - 1				Raccordi femmina DIN 11851 Connection male DIN 11851	
Rotore fino a 70°C up to 158°F	Rotore ridotto 70°C - 100°C 158°F - 212°F	Potenza minima installata Minimum installed power	Spinta assiale massima installata Maximum axial thrust installed	Passaggio sferico Sphere size	Portata teorica a giro Theoretical revolutional delivery	Bocca aspir. Suction port DN 80	
53,3 mm Eccentricità "h" 9,3 mm	52,8 mm Eccentricità "h" 9,3 mm	2,2 kW	2435 N Coppia di spunto Starting torque 56 Nm	36,7 mm Dimensione massima prodotto solido Maximum dimension of the solid product 4,5 mm	0,5 l	Bocca mand. Discharge port DN 80	

CARATTERISTICHE DI FUNZIONAMENTO CON ACQUA PULITA A 20°C - PESO SPECIFICO 1 (kg/dm³) - VISCOSITÀ 1 (cps)
Curves show performance with clear water at 68°F - Specific gravity 1 (kg/dm³) - Viscosity 1 (cps)

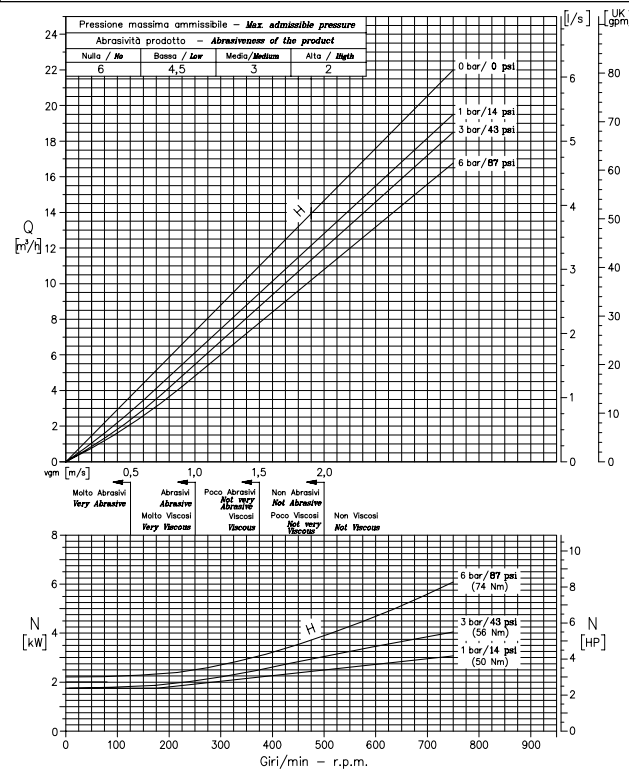

CURVE CARATTERISTICHE PERFORMANCE CURVES

Serie MONOVITE POSITIVE-DISPLACEMENT SCREW Series

POMPA TIPO Pump type		M 80 - 2		Raccordi femmina DIN 11851 Connection male DIN 11851	
Rotore fino a 70°C up to 158°F	Rotore ridotto 70°C - 100°C 158°F - 212°F	Potenza minima installata	Spinta assiale massima Maximum axial thrust	Passaggio sferico Sphere size	Portata teorica a giro Theoretical revolutional delivery
53,1 mm	52,8 mm	3 kW	4870 N	36,9 mm	4,498 l
9,3 mm	9,3 mm		78 Nm	4,5 mm	
Bocca aspir. DN 80					
Bocca mand. DN 80					
CARATTERISTICHE DI FUNZIONAMENTO CON ACQUA PULITA A 20°C - PESO SPECIFICO 1 (kg/dm ³) - VISCOSITA' 1 (cps) Curves show performance with clear water at 68°F - Specific gravity 1 (kg/dm ³) - Viscosity 1 (cps)					

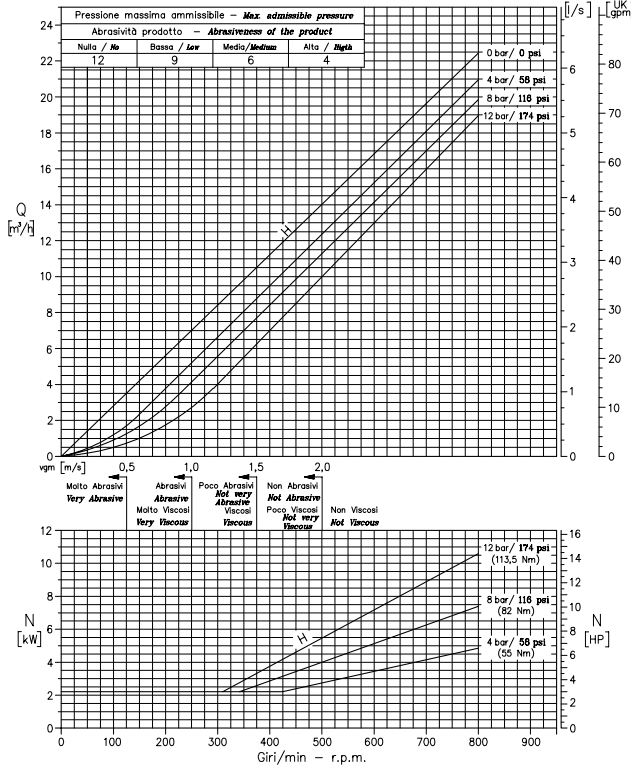

POMPA TIPO Pump type		M 80 - 2S		Raccordi femmina DIN 11851 Connection male DIN 11851	
Rotore fino a 70°C up to 158°F	Rotore ridotto 70°C - 100°C 158°F - 212°F	Potenza minima installata	Spinta assiale massima Maximum axial thrust	Passaggio sferico Sphere size	Portata teorica a giro Theoretical revolutional delivery
54,4 mm	54,2 mm	5,5 kW	9205 N	36,9 mm	0,51 l
9,3 mm	9,3 mm		170 Nm	4,5 mm	
Bocca aspir. DN 80					
Bocca mand. DN 80					
CARATTERISTICHE DI FUNZIONAMENTO CON ACQUA PULITA A 20°C - PESO SPECIFICO 1 (kg/dm ³) - VISCOSITA' 1 (cps) Curves show performance with clear water at 68°F - Specific gravity 1 (kg/dm ³) - Viscosity 1 (cps)					

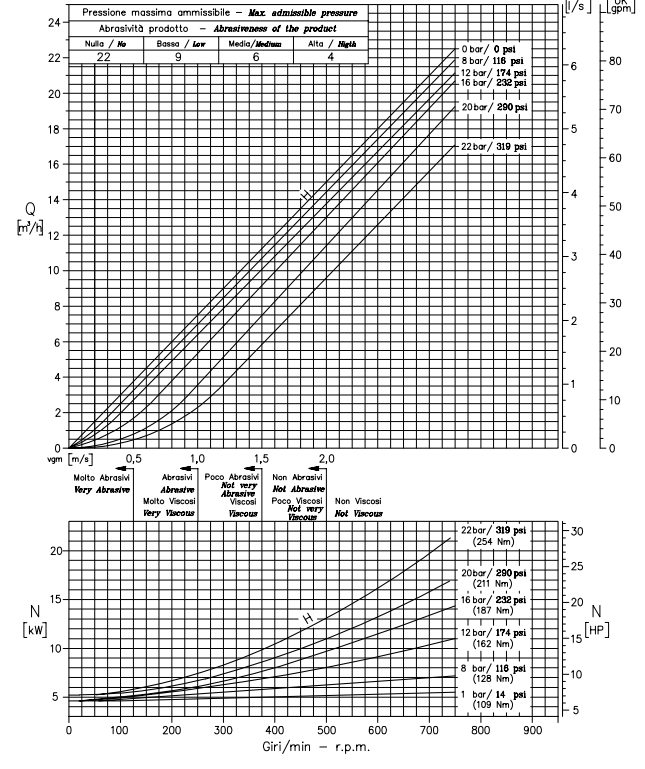

POMPA TIPO Pump type		M 80 - 4		Raccordi femmina DIN 11851 Connection male DIN 11851	
Rotore fino a 70°C up to 158°F	Rotore ridotto 70°C - 100°C 158°F - 212°F	Potenza minima installata	Spinta assiale massima Maximum axial thrust	Passaggio sferico Sphere size	Portata teorica a giro Theoretical revolutional delivery
53,5 mm	52,6 mm	5,5 kW	9795 N	37 mm	0,502 l
9,3 mm	9,4 mm		245 Nm	4 mm	
Bocca aspir. DN 80					
Bocca mand. DN 80					
CARATTERISTICHE DI FUNZIONAMENTO CON ACQUA PULITA A 20°C - PESO SPECIFICO 1 (kg/dm ³) - VISCOSITA' 1 (cps) Curves show performance with clear water at 68°F - Specific gravity 1 (kg/dm ³) - Viscosity 1 (cps)					

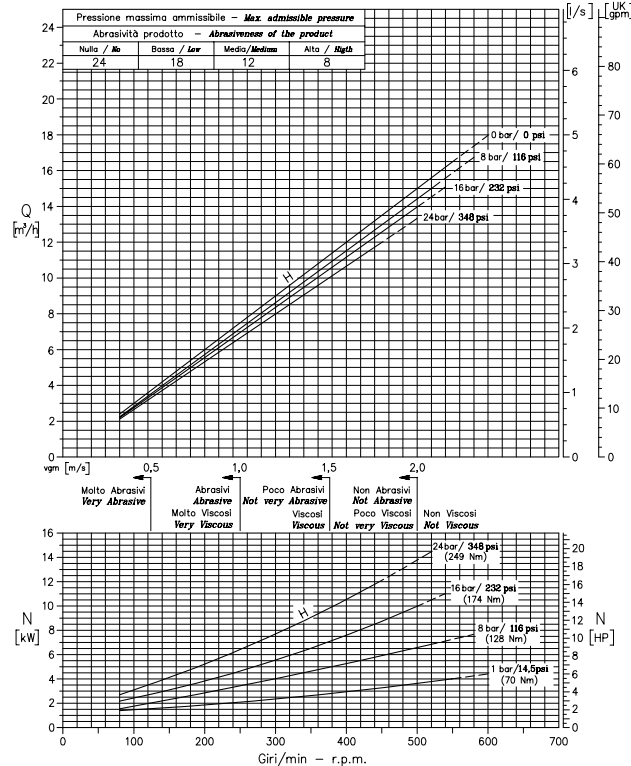

POMPA TIPO Pump type		M 83 - 1		Raccordi femmina DIN 11851 Connection male DIN 11851	
Rotore fino a 70°C up to 158°F	Rotore ridotto 70°C - 100°C 158°F - 212°F	Potenza minima installata	Spinta assiale massima Maximum axial thrust	Passaggio sferico Sphere size	Portata teorica a giro Theoretical revolutional delivery
54,5 / 78,5 mm	54,2 / 78,2 mm	3 kW	2775 N	15 mm	0,608 l
6 mm	6 mm		85 Nm	1,2 mm	
Bocca aspir. DN 80					
Bocca mand. DN 80					
CARATTERISTICHE DI FUNZIONAMENTO CON ACQUA PULITA A 20°C - PESO SPECIFICO 1 (kg/dm ³) - VISCOSITA' 1 (cps) Curves show performance with clear water at 68°F - Specific gravity 1 (kg/dm ³) - Viscosity 1 (cps)					

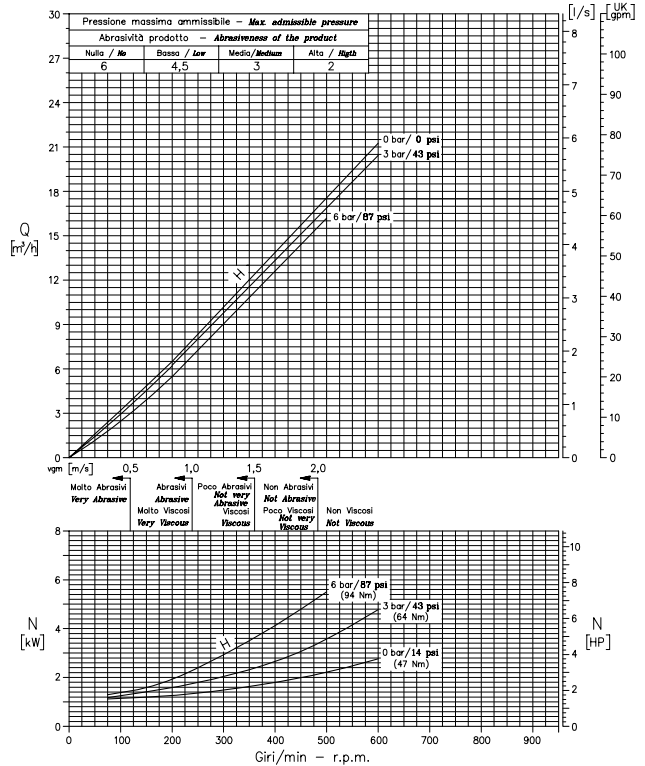

CURVE CARATTERISTICHE PERFORMANCE CURVES

Serie MONOVITE POSITIVE-DISPLACEMENT SCREW Series

POMPA TIPO Pump type		M 90 - L				Raccordi femmina DIN 11851 Connection male DIN 11851	
Rotore fino a 70°C up to 158°F	Rotore ridotto 70°C - 100°C 158°F - 212°F	Potenza minima installata Minimum installed power	Spinta assiale massima Maximum axial thrust	Passaggio sferico a giro Sphere size	Portata teorica a giro Theoretical revolutions delivery	Bocca aspir. Suction port DN 80	
53 mm	52,3 mm	4,8 kW	2990 N	41 mm	1,23 l	Bocca mand. Discharge port DN 80	
Eccentricità "h" Eccentricity	10,3 mm		Coppia di spunto Starting torque 97 Nm	Dimensione massima prodotto solido Maximum dimension of the solid product 5 mm			

CARATTERISTICHE DI FUNZIONAMENTO CON ACQUA PULITA A 20°C - PESO SPECIFICO 1 (kg/dm³) - VISCOSITÀ 1 (cps)
Curves show performance with clear water at 68°F - Specific gravity 1 (kg/dm³) - Viscosity 1 (cps)

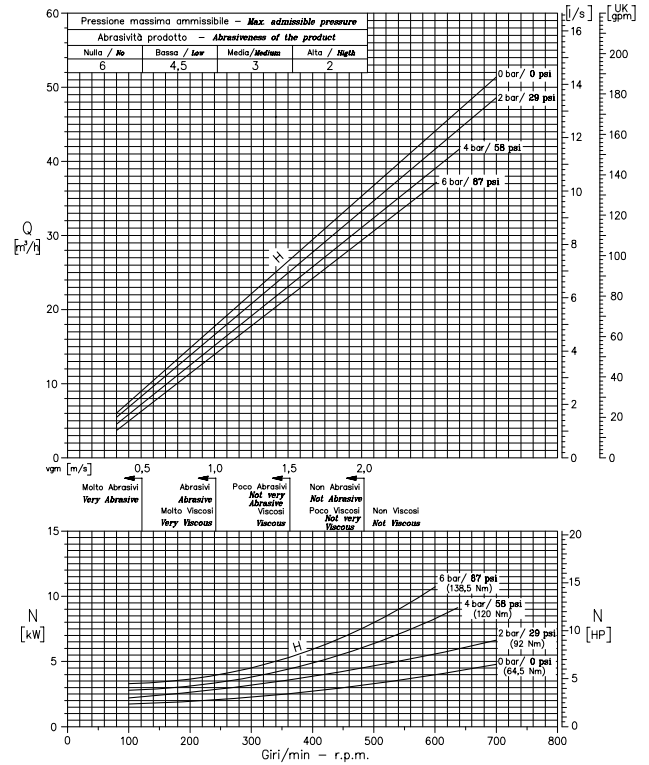

POMPA TIPO Pump type		M 100 - 1				Raccordi femmina DIN 11851 Connection male DIN 11851	
Rotore fino a 70°C up to 158°F	Rotore ridotto 70°C - 100°C 158°F - 212°F	Potenza minima installata Minimum installed power	Spinta assiale massima Maximum axial thrust	Passaggio sferico a giro Sphere size	Portata teorica a giro Theoretical revolutions delivery	Bocca aspir. Suction port DN 100	
65,4 mm	64,7 mm	4 kW	3600 N	43,4 mm	0,881 l	Bocca mand. Discharge port DN 100	
Eccentricità "h" Eccentricity	11 mm		Coppia di spunto Starting torque 85 Nm	Dimensione massima prodotto solido Maximum dimension of the solid product 6,5 mm			

CARATTERISTICHE DI FUNZIONAMENTO CON ACQUA PULITA A 20°C - PESO SPECIFICO 1 (kg/dm³) - VISCOSITÀ 1 (cps)
Curves show performance with clear water at 68°F - Specific gravity 1 (kg/dm³) - Viscosity 1 (cps)

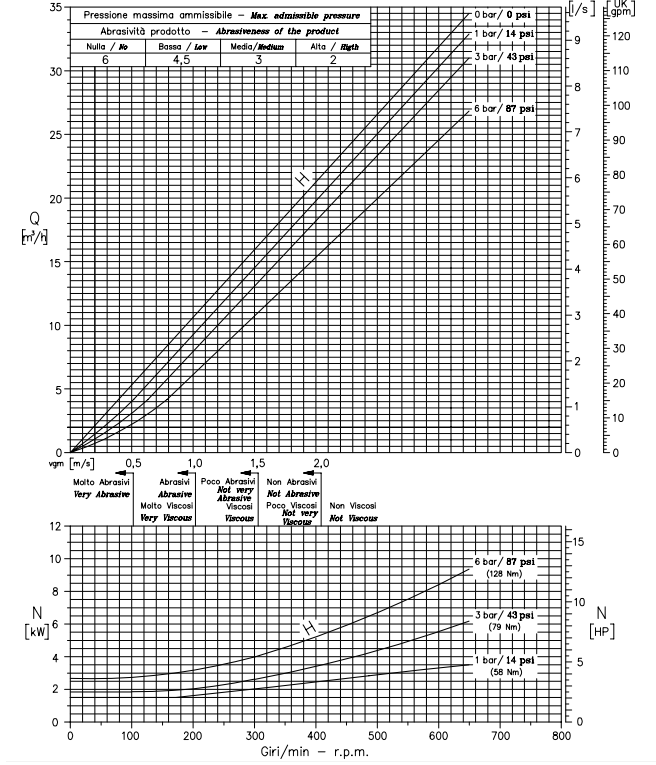

POMPA TIPO Pump type		M 100 - 2				Raccordi femmina DIN 11851 Connection male DIN 11851	
Rotore fino a 70°C up to 158°F	Rotore ridotto 70°C - 100°C 158°F - 212°F	Potenza minima installata Minimum installed power	Spinta assiale massima Maximum axial thrust	Passaggio sferico a giro Sphere size	Portata teorica a giro Theoretical revolutions delivery	Bocca aspir. Suction port DN 100	
65,3 mm	64,6 mm	5,5 kW	7180 N	43,5 mm	0,879 l	Bocca mand. Discharge port DN 100	
Eccentricità "h" Eccentricity	11 mm		Coppia di spunto Starting torque 175 Nm	Dimensione massima prodotto solido Maximum dimension of the solid product 6,5 mm			

CARATTERISTICHE DI FUNZIONAMENTO CON ACQUA PULITA A 20°C - PESO SPECIFICO 1 (kg/dm³) - VISCOSITÀ 1 (cps)
Curves show performance with clear water at 68°F - Specific gravity 1 (kg/dm³) - Viscosity 1 (cps)

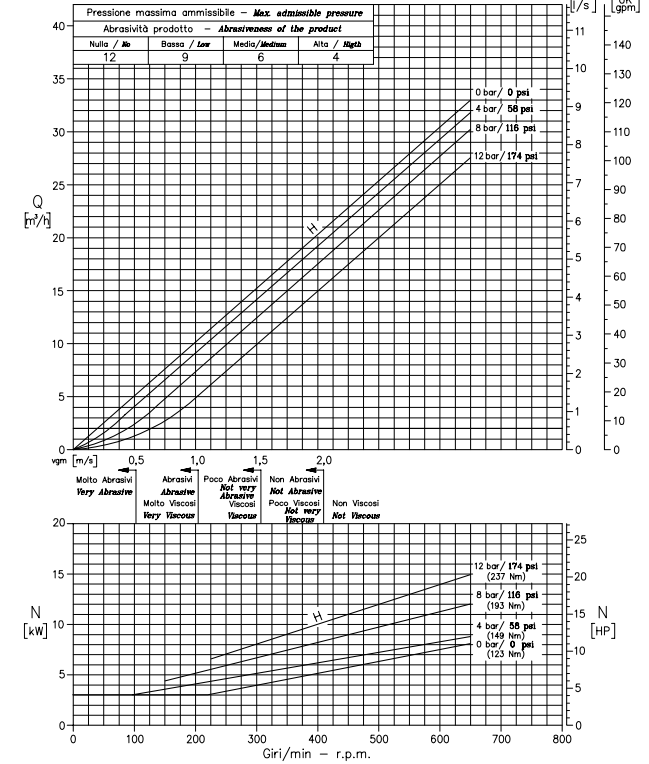

POMPA TIPO Pump type		M 100 - 2S				Raccordi femmina DIN 11851 Connection male DIN 11851	
Rotore fino a 70°C up to 158°F	Rotore ridotto 70°C - 100°C 158°F - 212°F	Potenza minima installata Minimum installed power	Spinta assiale massima Maximum axial thrust	Passaggio sferico a giro Sphere size	Portata teorica a giro Theoretical revolutions delivery	Bocca aspir. Suction port DN 100	
65,5 mm	---	7,5 kW	13220 N	43,5 mm	0,882 l	Bocca mand. Discharge port DN 100	
Eccentricità "h" Eccentricity	11 mm		Coppia di spunto Starting torque 298 Nm	Dimensione massima prodotto solido Maximum dimension of the solid product 6,5 mm			

CARATTERISTICHE DI FUNZIONAMENTO CON ACQUA PULITA A 20°C - PESO SPECIFICO 1 (kg/dm³) - VISCOSITÀ 1 (cps)
Curves show performance with clear water at 68°F - Specific gravity 1 (kg/dm³) - Viscosity 1 (cps)

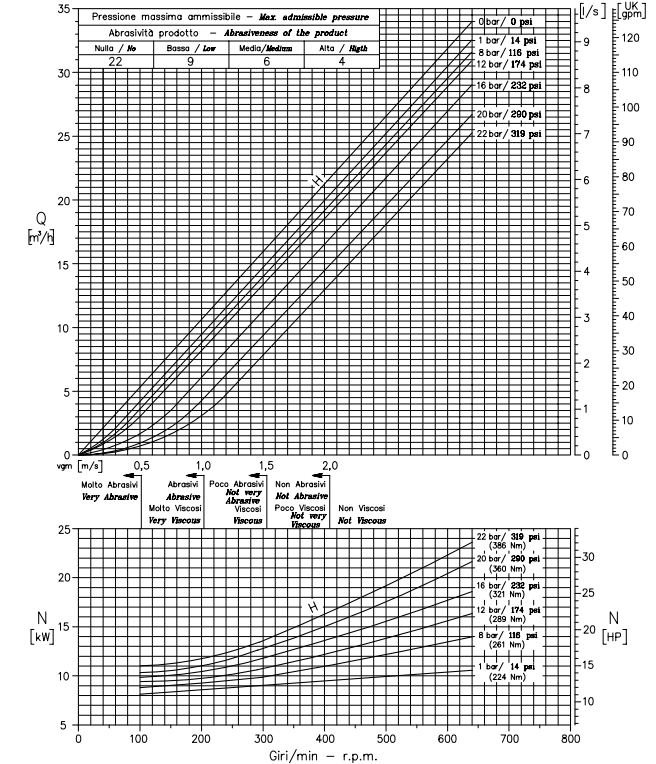

CURVE CARATTERISTICHE

PERFORMANCE CURVES

Serie MONOVITE

POSITIVE-DISPLACEMENT SCREW Series

POMPA TIPO M 100 - 4					Raccordi femmina DIN 11851	
Pump type					Connection male DIN 11851	
Rotore fino a 70°C up to 158°F	Rotore ridotto fino a 70°C up to 158°F	Potenza minima installata	Spinta assiale massima	Passaggio sferico	Portata teorica a giro	Bocca aspir. DN 100 Bocca mand. DN 100
65,3 mm	64,1 mm	7,5 kW	14555 N	44,9 mm	0,903 l	
Eccentricità "h" 11,3 mm	Eccentricità "h" 11,5 mm		Coppia di spunto	Dimensione massima prodotto solido		
			350 Nm	6 mm		

CARATTERISTICHE DI FUNZIONAMENTO CON ACQUA PULITA A 20°C - PESO SPECIFICO 1 (kg/dm³) - VISCOSITÀ 1 (cps)

Curves show performance with clear water at 68°F - Specific gravity 1 (kg/dm³) - Viscosity 1 (cps)

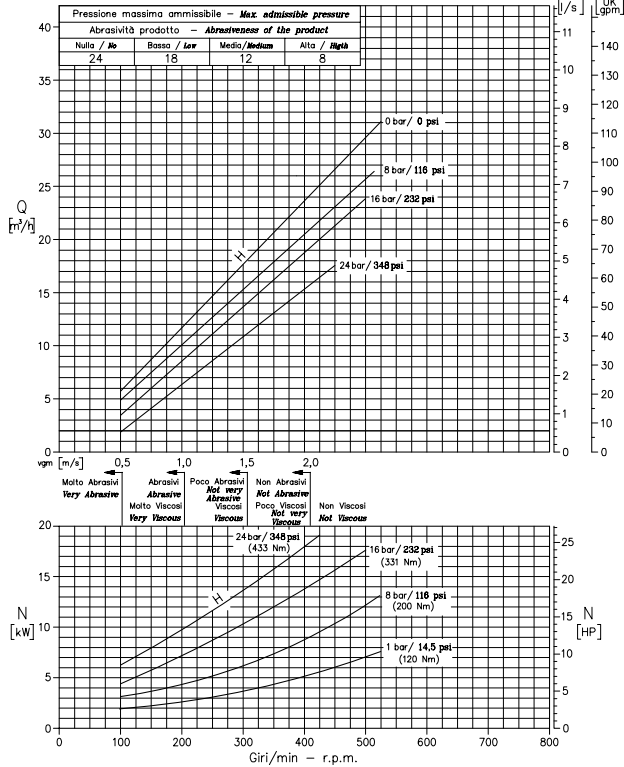

POMPA TIPO M 103 - 1					Raccordi femmina DIN 11851	
Pump type					Connection male DIN 11851	
Rotore fino a 70°C up to 158°F	Rotore ridotto fino a 70°C up to 158°F	Potenza minima installata	Spinta assiale massima	Passaggio sferico	Portata teorica a giro	Bocca aspir. DN 100 Bocca mand. DN 100
68,5 / 98,1 mm	68,5 / 98,1 mm	3 kW	3050 N	19 mm	1,397 l	
Eccentricità "h" 5,5 mm	Eccentricità "h" 5,5 mm		Coppia di spunto	Dimensione massima prodotto solido		
			125 Nm	2 mm		

CARATTERISTICHE DI FUNZIONAMENTO CON ACQUA PULITA A 20°C - PESO SPECIFICO 1 (kg/dm³) - VISCOSITÀ 1 (cps)

Curves show performance with clear water at 68°F - Specific gravity 1 (kg/dm³) - Viscosity 1 (cps)

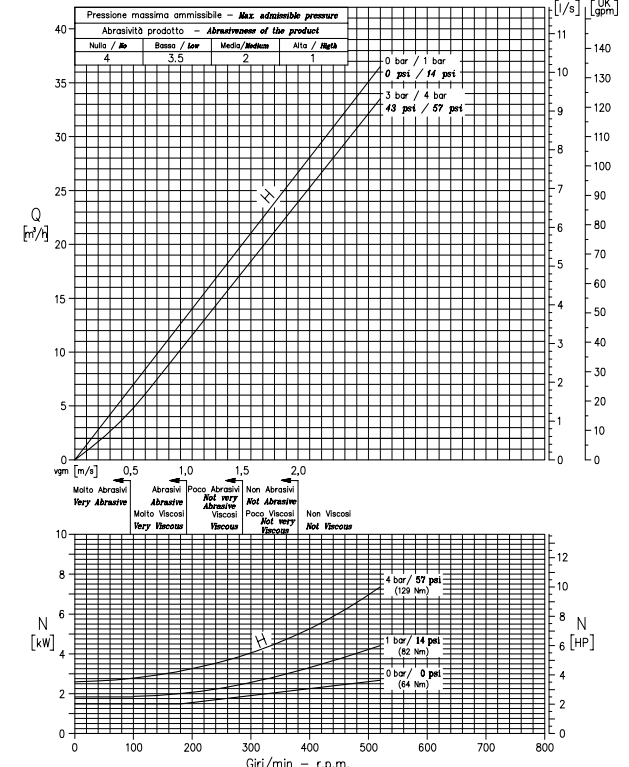

POMPA TIPO M 110 - L					Raccordi femmina DIN 11851	
Pump type					Connection male DIN 11851	
Rotore fino a 70°C up to 158°F	Rotore ridotto fino a 70°C up to 158°F	Potenza minima installata	Spinta assiale massima	Passaggio sferico	Portata teorica a giro	Bocca aspir. DN 100 Bocca mand. DN 100
63,4 mm	62,4 mm	5,5 kW	3715 N	50,7 mm	2,023 l	
Eccentricità "h" 12,7 mm	Eccentricità "h" 12,9 mm		Coppia di spunto	Dimensione massima prodotto solido		
			130 Nm	7 mm		

CARATTERISTICHE DI FUNZIONAMENTO CON ACQUA PULITA A 20°C - PESO SPECIFICO 1 (kg/dm³) - VISCOSITÀ 1 (cps)

Curves show performance with clear water at 68°F - Specific gravity 1 (kg/dm³) - Viscosity 1 (cps)

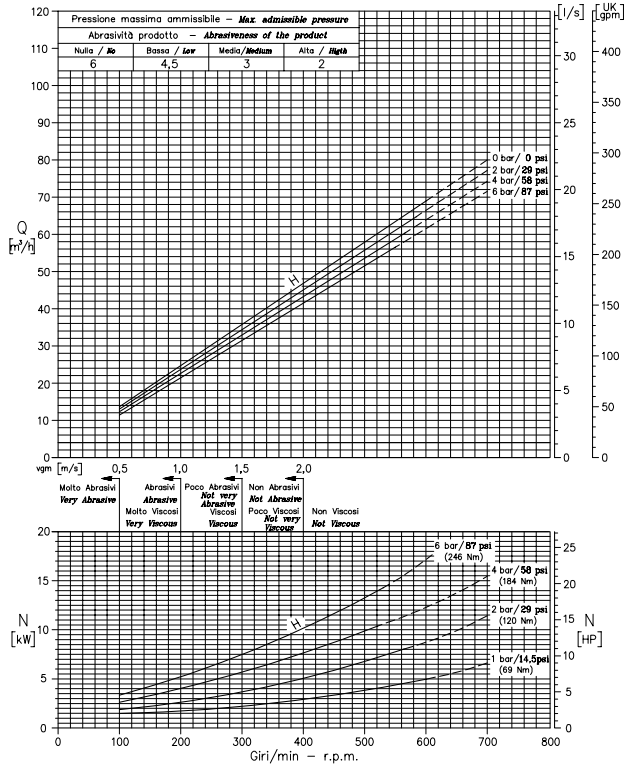

POMPA TIPO M 115 - 1					Raccordi femmina DIN 11851	
Pump type					Connection male DIN 11851	
Rotore fino a 70°C up to 158°F	Rotore ridotto fino a 70°C up to 158°F	Potenza minima installata	Spinta assiale massima	Passaggio sferico	Portata teorica a giro	Bocca aspir. DN 100 Bocca mand. DN 100
72 mm	71,2 mm	5,5 kW	4525 N	51,7 mm	1,31 l	
Eccentricità "h" 13 mm	Eccentricità "h" 13 mm		Coppia di spunto	Dimensione massima prodotto solido		
			100 Nm	7,5 mm		

CARATTERISTICHE DI FUNZIONAMENTO CON ACQUA PULITA A 20°C - PESO SPECIFICO 1 (kg/dm³) - VISCOSITÀ 1 (cps)

Curves show performance with clear water at 68°F - Specific gravity 1 (kg/dm³) - Viscosity 1 (cps)

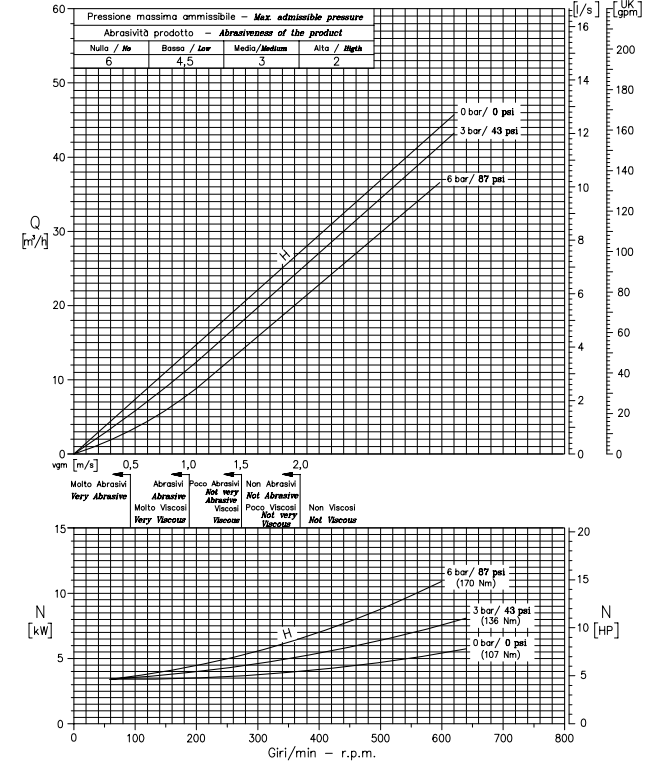

CURVE CARATTERISTICHE

PERFORMANCE CURVES

Serie MONOVITE

POSITIVE-DISPLACEMENT SCREW Series

POMPA TIPO		M 115 - 2				Raccordi femmina	
Pump type						DIN 11851	
Rotore fino a 70°C up to 158°F	Rotore ridotto fino a 70°C up to 158°F	Potenza minima installata	Spianta assiale massima	Passaggio sferico	Portata teorica a giro	Bocca aspir. DN 100	
72 mm	71,2 mm	7,5 kW	9045 N	51,7 mm	1,31 l	Bocca mand. DN 100	
13 mm	13 mm		215 Nm	7,5 mm			

CARATTERISTICHE DI FUNZIONAMENTO CON ACQUA PULITA A 20°C - PESO SPECIFICO 1 (kg/dm³) - VISCOSITÀ 1 (cps)
Curves show performance with clear water at 68°F - Specific gravity 1 (kg/dm³) - Viscosity 1 (cps)

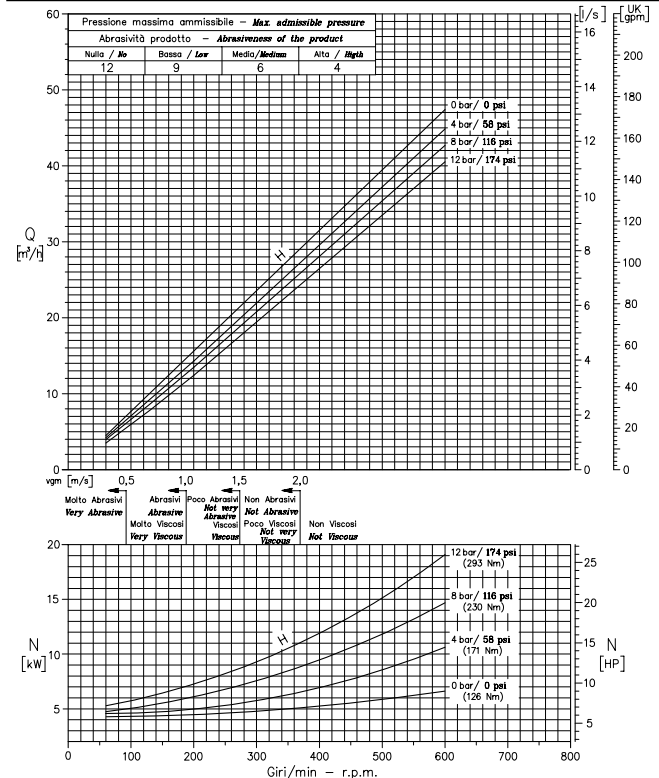

POMPA TIPO		M 125 - 1				Raccordi femmina	
Pump type						DIN 11851	
Rotore fino a 70°C up to 158°F	Rotore ridotto fino a 70°C up to 158°F	Potenza minima installata	Spianta assiale massima	Passaggio sferico	Portata teorica a giro	Bocca aspir. DN 100	
81,6 mm	80,9 mm	7,5 kW	5825 N	58,4 mm	1,932 l	Bocca mand. DN 100	
14,8 mm	14,8 mm		180 Nm	9 mm			

CARATTERISTICHE DI FUNZIONAMENTO CON ACQUA PULITA A 20°C - PESO SPECIFICO 1 (kg/dm³) - VISCOSITÀ 1 (cps)
Curves show performance with clear water at 68°F - Specific gravity 1 (kg/dm³) - Viscosity 1 (cps)

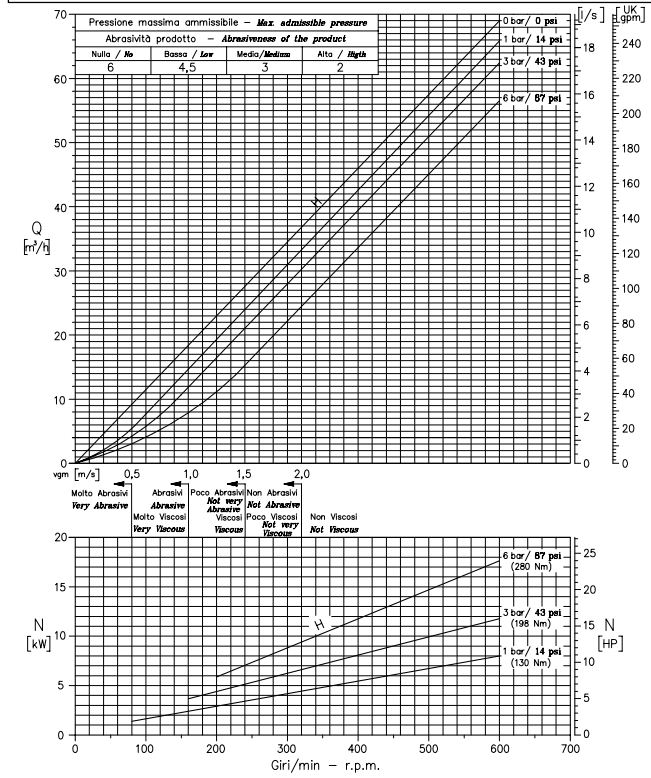

POMPA TIPO		M 125 - 2				Raccordi femmina	
Pump type						DIN 11851	
Rotore fino a 70°C up to 158°F	Rotore ridotto fino a 70°C up to 158°F	Potenza minima installata	Spianta assiale massima	Passaggio sferico	Portata teorica a giro	Bocca aspir. DN 100	
81,4 mm	80,7 mm	9,2 kW	11605 N	58,6 mm	1,928 l	Bocca mand. DN 100	
14,8 mm	14,8 mm		390 Nm	9 mm			

CARATTERISTICHE DI FUNZIONAMENTO CON ACQUA PULITA A 20°C - PESO SPECIFICO 1 (kg/dm³) - VISCOSITÀ 1 (cps)
Curves show performance with clear water at 68°F - Specific gravity 1 (kg/dm³) - Viscosity 1 (cps)

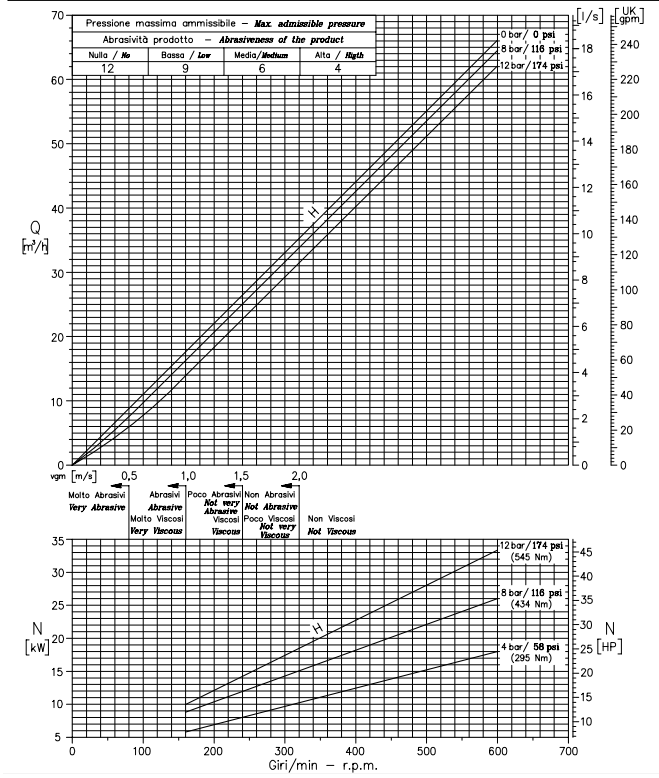

POMPA TIPO		M 125 - 2S				Raccordi femmina	
Pump type						DIN 11851	
Rotore fino a 70°C up to 158°F	Rotore ridotto fino a 70°C up to 158°F	Potenza minima installata	Spianta assiale massima	Passaggio sferico	Portata teorica a giro	Bocca aspir. DN 100	
82,5 mm	81,4 mm	9,2 kW	19730 N	58,6 mm	1,954 l	Bocca mand. DN 100	
14,8 mm	14,8 mm		524 Nm	9 mm			

CARATTERISTICHE DI FUNZIONAMENTO CON ACQUA PULITA A 20°C - PESO SPECIFICO 1 (kg/dm³) - VISCOSITÀ 1 (cps)
Curves show performance with clear water at 68°F - Specific gravity 1 (kg/dm³) - Viscosity 1 (cps)

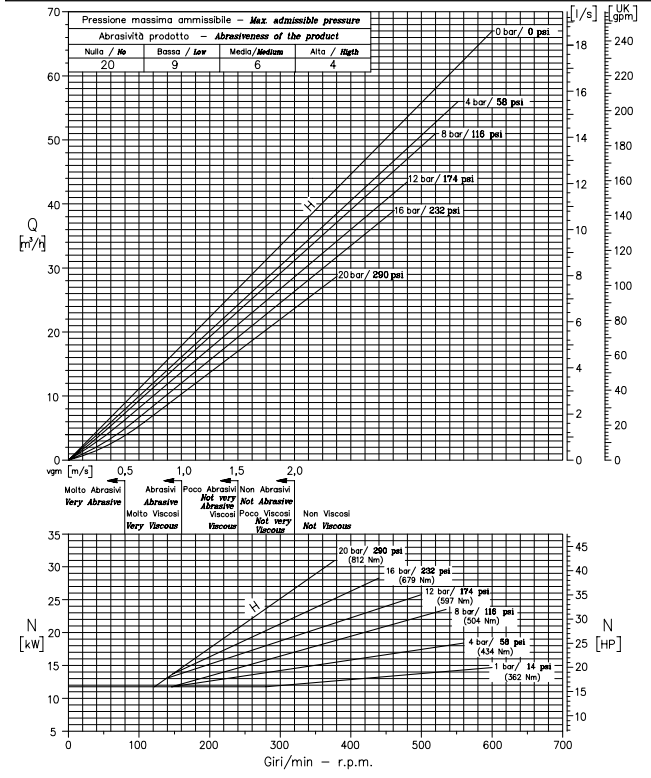

CURVE CARATTERISTICHE

PERFORMANCE CURVES

Serie MONOVITE

POSITIVE-DISPLACEMENT SCREW Series

POMPA TIPO		M 125 - 4				Raccordi femmina	
Pump type						DIN 11851	
Rotore fino a 70°C up to 158°F	Rotore ridotto fino a 100°C 158°F - 212°F	Potenza minima installata	Spinta assiale massima	Passaggio sferico	Portata teorica a giro	Bocca aspir. DN 100	
80 mm	78,5 mm	11 kW	23630 N	63,7 mm	2,05 l	Bocca mand. DN 100	
Eccentricità "h" Eccentricity			Coppia di spunto	Dimensione massima prodotto solido			
16 mm	16,25 mm		610 Nm	8 mm			

CARATTERISTICHE DI FUNZIONAMENTO CON ACQUA PULITA A 20°C - PESO SPECIFICO 1 (kg/dm³) - VISCOSITÀ 1 (cps)
Curves show performance with clear water at 68°F - Specific gravity 1 (kg/dm³) - Viscosity 1 (cps)

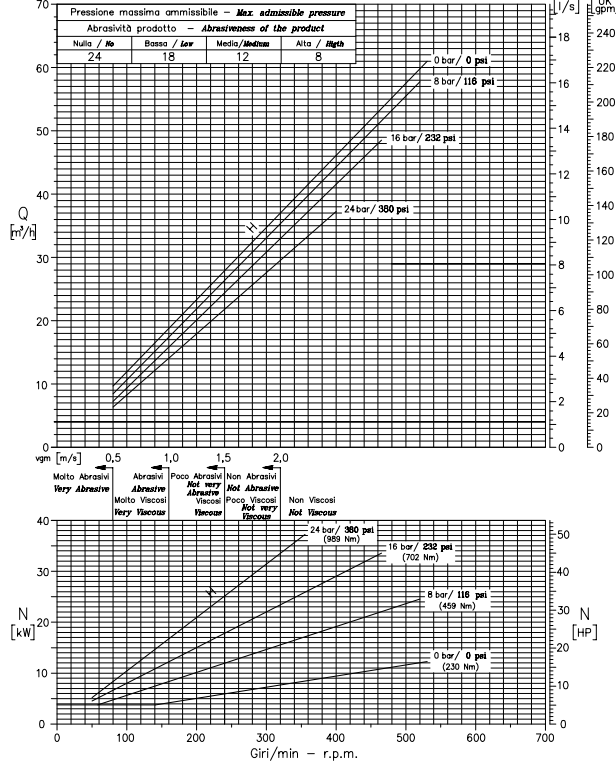

POMPA TIPO		M 130 - L				Raccordi femmina	
Pump type						DIN 11851	
Rotore fino a 70°C up to 158°F	Rotore ridotto fino a 100°C 158°F - 212°F	Potenza minima installata	Spinta assiale massima	Passaggio sferico	Portata teorica a giro	Bocca aspir. DN 100	
76,7 mm	76 mm	7,5 kW	4960 N	50,6 mm	2,86 l	Bocca mand. DN 100	
Eccentricità "h" Eccentricity			Coppia di spunto	Dimensione massima prodotto solido			
12,95 mm	12,95 mm		190 Nm	7,5 mm			

CARATTERISTICHE DI FUNZIONAMENTO CON ACQUA PULITA A 20°C - PESO SPECIFICO 1 (kg/dm³) - VISCOSITÀ 1 (cps)
Curves show performance with clear water at 68°F - Specific gravity 1 (kg/dm³) - Viscosity 1 (cps)

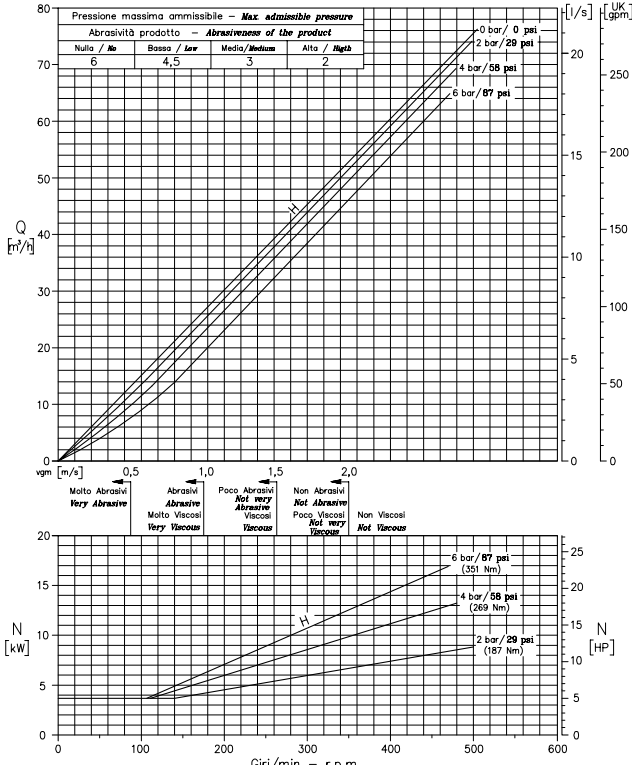

POMPA TIPO		M 140 - L				Flange	
Pump type						UNI EN 1092-1	
Rotore fino a 70°C up to 158°F	Rotore ridotto fino a 100°C 158°F - 212°F	Potenza minima installata	Spinta assiale massima	Passaggio sferico	Portata teorica a giro	Bocca aspir. DN 150	
83,9 mm	82,7 mm	7,5 kW	5980 N	55 mm	3,89 l	Bocca mand. DN 125	
Eccentricità "h" Eccentricity			Coppia di spunto	Dimensione massima prodotto solido			
14,55 mm	14,6 mm		600 Nm	8 mm			

CARATTERISTICHE DI FUNZIONAMENTO CON ACQUA PULITA A 20°C - PESO SPECIFICO 1 (kg/dm³) - VISCOSITÀ 1 (cps)
Curves show performance with clear water at 68°F - Specific gravity 1 (kg/dm³) - Viscosity 1 (cps)

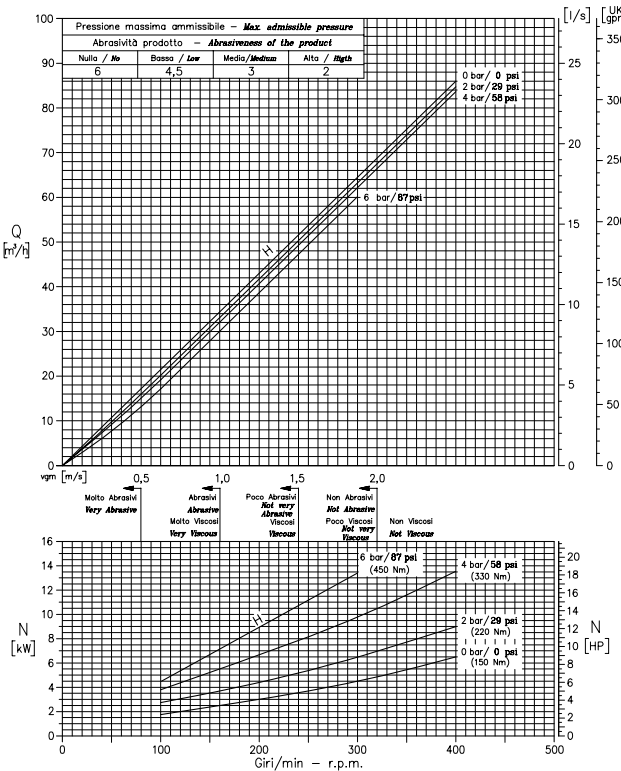

POMPA TIPO		M 150 - 1				Flange	
Pump type						UNI EN 1092-1	
Rotore fino a 70°C up to 158°F	Rotore ridotto fino a 100°C 158°F - 212°F	Potenza minima installata	Spinta assiale massima	Passaggio sferico	Portata teorica a giro	Bocca aspir. DN 150	
100,5 mm	99,8 mm	9,2 kW	9300 N	78,8 mm	4,02 l	Bocca mand. DN 150	
Eccentricità "h" Eccentricity			Coppia di spunto	Dimensione massima prodotto solido			
20 mm	20 mm		435 Nm	12 mm			

CARATTERISTICHE DI FUNZIONAMENTO CON ACQUA PULITA A 20°C - PESO SPECIFICO 1 (kg/dm³) - VISCOSITÀ 1 (cps)
Curves show performance with clear water at 68°F - Specific gravity 1 (kg/dm³) - Viscosity 1 (cps)

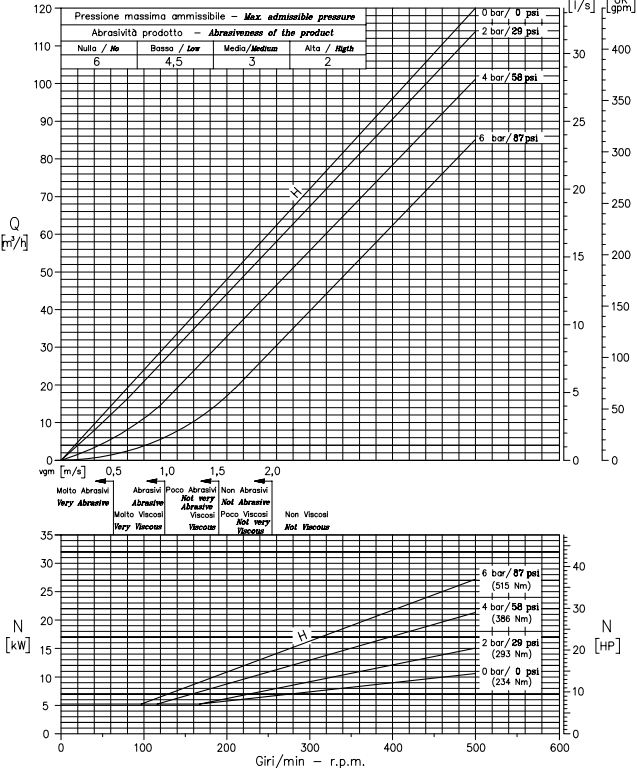

CURVE CARATTERISTICHE

PERFORMANCE CURVES

Serie MONOVITE

POSITIVE-DISPLACEMENT SCREW Series

POMPA TIPO		M 150 - 1S				Flange	
Pump type						UNI EN 1092-1	
Rotore ridotto fino a 70°C up to 158°F	Rotore ridotto fino a 70°C up to 158°F	Potenza minima installata	Spinta assiale massima	Passaggio sferico	Portata teorica a giro	Flanges UNI EN 1092-1	
100,5 mm	100,5 mm	15 kW	15500 N	78,8 mm	4,02 l	Bocca aspir.	DN 150
20 mm	20 mm		595 Nm	12 mm		Bocca mand.	DN 150
CARATTERISTICHE DI FUNZIONAMENTO CON ACQUA PULITA A 20°C - PESO SPECIFICO 1 (kg/dm ³) - VISCOSITA' 1 (cps) Curves show performance with clear water at 68°F - Specific gravity 1 (kg/dm ³) - Viscosity 1 (cps)							

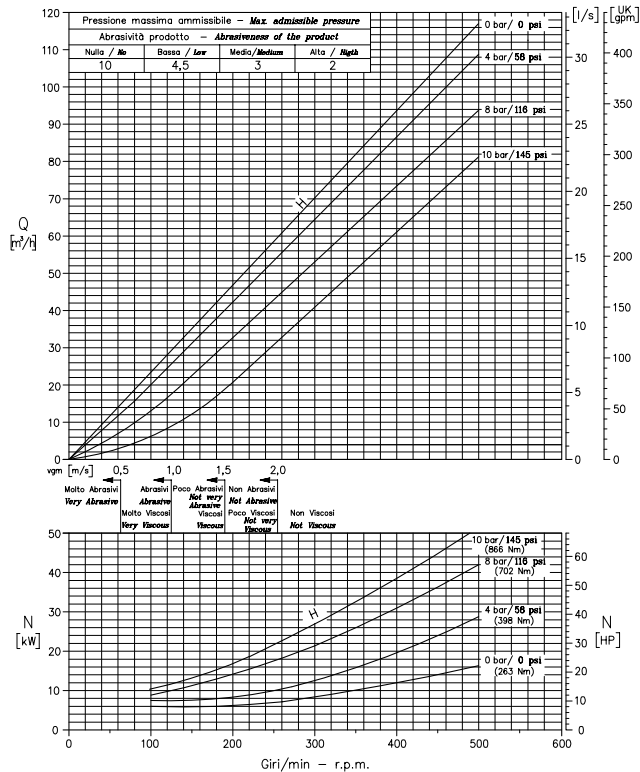

POMPA TIPO		M 150 - 2				Flange	
Pump type						UNI EN 1092-1	
Rotore ridotto fino a 70°C up to 158°F	Rotore ridotto fino a 70°C up to 158°F	Potenza minima installata	Spinta assiale massima	Passaggio sferico	Portata teorica a giro	Flanges UNI EN 1092-1	
100 mm	100 mm	15 kW	18465 N	79,7 mm	4 l	Bocca aspir.	DN 150
20 mm	20 mm		98,6 mm	11,5 mm		Bocca mand.	DN 150
CARATTERISTICHE DI FUNZIONAMENTO CON ACQUA PULITA A 20°C - PESO SPECIFICO 1 (kg/dm ³) - VISCOSITA' 1 (cps) Curves show performance with clear water at 68°F - Specific gravity 1 (kg/dm ³) - Viscosity 1 (cps)							

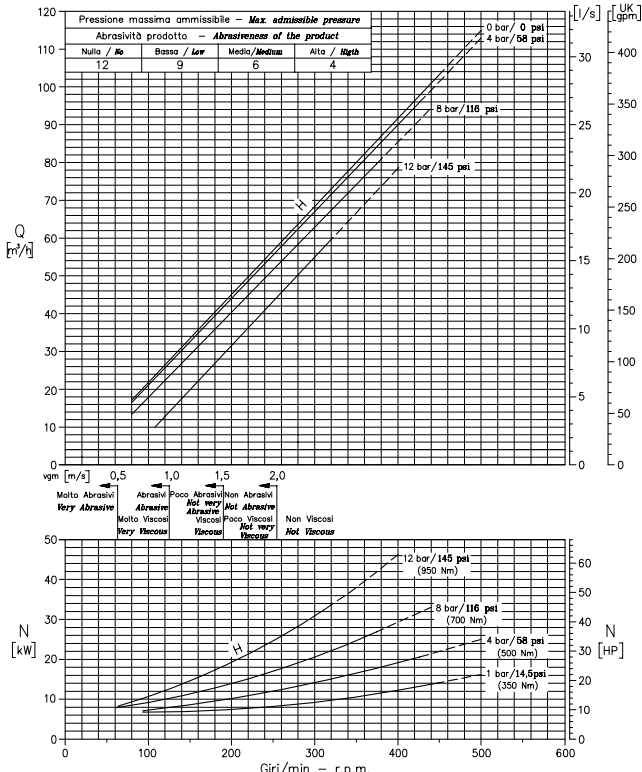

POMPA TIPO		M 151 - 1.5				Flange	
Pump type						UNI EN 1092-1	
Rotore ridotto fino a 70°C up to 158°F	Rotore ridotto fino a 70°C up to 158°F	Potenza minima installata	Spinta assiale massima	Passaggio sferico	Portata teorica a giro	Flanges UNI EN 1092-1	
113,3 mm	113,3 mm	11 kW	17481 N	86 mm	5,48 l	Bocca aspir.	DN 150
22 mm	22,1 mm		800 Nm	12 mm		Bocca mand.	DN 200
CARATTERISTICHE DI FUNZIONAMENTO CON ACQUA PULITA A 20°C - PESO SPECIFICO 1 (kg/dm ³) - VISCOSITA' 1 (cps) Curves show performance with clear water at 68°F - Specific gravity 1 (kg/dm ³) - Viscosity 1 (cps)							

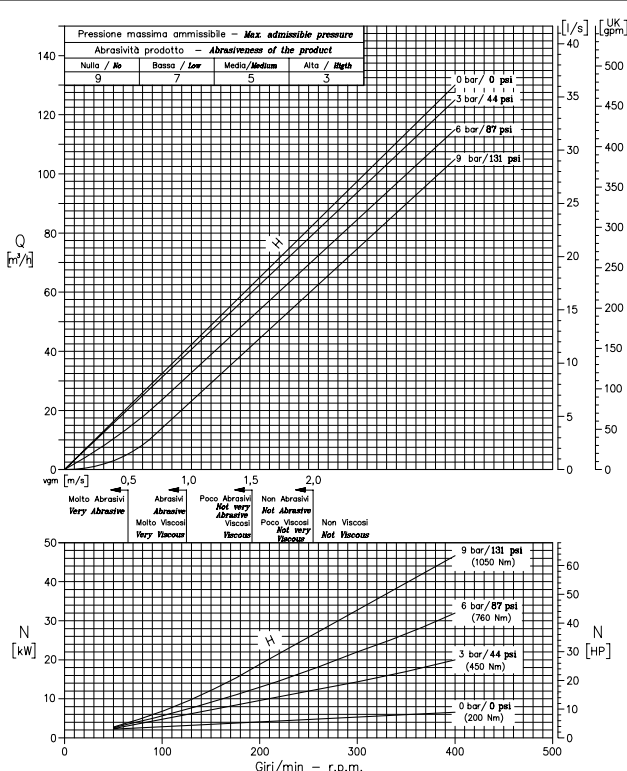

POMPA TIPO		M 160 - L				Flange	
Pump type						UNI EN 1092-1	
Rotore ridotto fino a 70°C up to 158°F	Rotore ridotto fino a 70°C up to 158°F	Potenza minima installata	Spinta assiale massima	Passaggio sferico	Portata teorica a giro	Flanges UNI EN 1092-1	
102,7 mm	101 mm	11 kW	9165 N	73,4 mm	7,62 l	Bocca aspir.	DN 150
18,4 mm	20 mm		950 Nm	11 mm		Bocca mand.	DN 150
CARATTERISTICHE DI FUNZIONAMENTO CON ACQUA PULITA A 20°C - PESO SPECIFICO 1 (kg/dm ³) - VISCOSITA' 1 (cps) Curves show performance with clear water at 68°F - Specific gravity 1 (kg/dm ³) - Viscosity 1 (cps)							

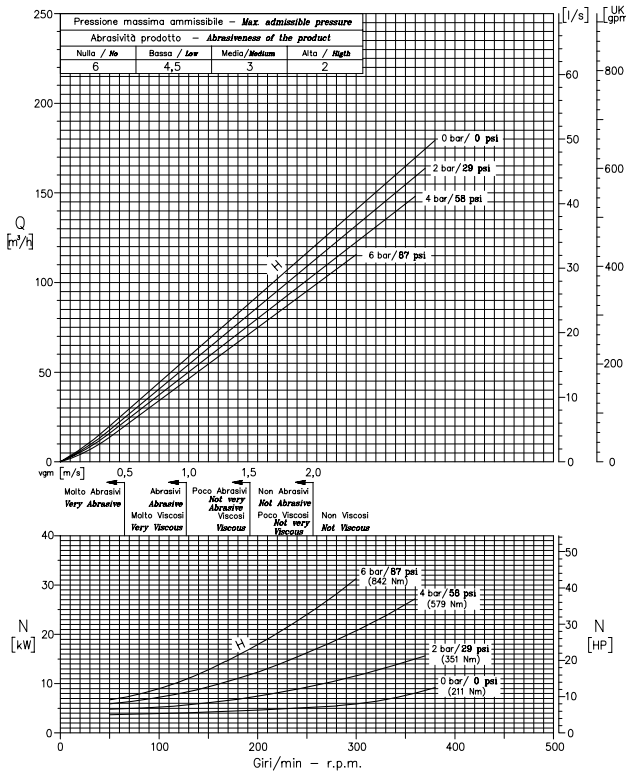

CURVE CARATTERISTICHE PERFORMANCE CURVES

Serie MONOVITE POSITIVE-DISPLACEMENT SCREW Series

POMPA TIPO Pump type		M 200 - 2		Flange UNI EN 1092-1 Flanges UNI EN 1092-1	
Rotore Rotor fino a 70°C up to 158°F	Rotore ridotto Reduced rotor 70°C - 180°C 158°F - 212°F	Potenza minima installata Minimum installed power	Spinta assiale massima Maximum axial thrust	Passaggio sferico Sphere size	Portata teorica a giro Theoretical revolutional delivery
125 mm	122,5 mm	11 kW	28850 N	99,7 mm	8,25 l
Eccentricità eccentricity	Eccentricità eccentricity		Coppia di spunto Starting torque	Dimensione massima prodotta solida Maximum dimension of the solid product	
25 mm	25,5 mm		1360 Nm	14 mm	
CARATTERISTICHE DI FUNZIONAMENTO CON ACQUA PULITA A 20°C - PESO SPECIFICO 1 (kg/dm ³) - VISCOSITÀ 1 (cps) Curves show performance with clear water at 68°F - Specific gravity 1 (kg/dm ³) - Viscosity 1 (cps)					

POMPA TIPO Pump type		M 200 - L		Flange UNI EN 1092-1 Flanges UNI EN 1092-1	
Rotore Rotor fino a 70°C up to 158°F	Rotore ridotto Reduced rotor 70°C - 180°C 158°F - 212°F	Potenza minima installata Minimum installed power	Spinta assiale massima Maximum axial thrust	Passaggio sferico Sphere size	Portata teorica a giro Theoretical revolutional delivery
125 mm	122,3 mm	11 kW	14500 N	99,7 mm	8,25 l
Eccentricità eccentricity	Eccentricità eccentricity		Coppia di spunto Starting torque	Dimensione massima prodotta solida Maximum dimension of the solid product	
25 mm	25,5 mm		1450 Nm	14 mm	16,25 l
CARATTERISTICHE DI FUNZIONAMENTO CON ACQUA PULITA A 20°C - PESO SPECIFICO 1 (kg/dm ³) - VISCOSITÀ 1 (cps) Curves show performance with clear water at 68°F - Specific gravity 1 (kg/dm ³) - Viscosity 1 (cps)					

