



# HYGIENIC CENTRIFUGAL AND SELF-PRIMING PUMPS

## 3A - EHEDG STANDARDS



### SERIES CSA - ASH

**CERTIFICATE OF COMPLIANCE**

**EHEDG**

TYPE 01 - CLASS 1

TUM Certification  
benefits derived from the product

Centrifugal pump with CSA and EPDM or PTFE gaskets material used  
- 3A, EHEDG standard

Name  
**CSFR S.p.A. - 13027, Moncalvo, Italy**

You have evaluated the compliance with the  
Hygiene Standards (Type 01) of the EHEDG, by  
TUW 11148 Requirements for pumps of 1.1 dimensions (up to 1000 mm diameter), geometry  
and more 01 criteria as dimensional fit.

Evaluation Report No. 07724 (1/2011) Date: 28 November 2011

Signed: *[Signature]* Date: 28 November 2011

By: *[Signature]* Evaluation Officer

In the presence of: *[Signature]* Date: 28 November 2011

TUM **TECHNISCHE UNIVERSITÄT MÜNCHEN**

3A/3B Pumping Installation, Lechbruck  
Kempten

---

ISSUE DATE: June 21, 1995      CERTIFICATE AUTHORIZATION NUMBER: 759

**3**

THIS IS TO CERTIFY THAT

CSFR S.p.A. Italy

is hereby authorized to produce to apply the  
3-A Symbol in the results of operations, conforming to 3-A Sanitary Standards for:

Number 02-11  
(2-11 (Centrifugal and Positive Rotary Pumps))

on both below

CSFR Models: Centrifugal pumps: CHV, CHS, and CHS, with type 10 mechanical seal, CSA, all sizes, with  
type 7, 10 or 12 mechanical seals, CSAG, all sizes, with type 10 mechanical seal, APS, all sizes, with  
type 10 mechanical seal.

Type Self-priming: TSE, TSD, with dual ball bearing mechanical seals

VALID THROUGH: December 31, 2017

Issued by: **R. Ruff**  
European Director  
3-A Sanitary Standards, Inc.

The issuance of this authorization for the use of the 3-A Symbol is based upon the voluntary certification, by the  
applicant for 3-A, that its operations meet above mentioned 3-A Sanitary Standards Requirements.  
Legal responsibility for compliance is solely that of the holder of this Certificate of Authorization, and 3-A  
Sanitary Standards, Inc. does not accept the liability for any performance of all those operating with the  
provision of the said 3-A Sanitary Standards. This is in no way to be taken as the responsibility of 3-A Sanitary Standards,  
Inc. in the appropriate action to take upon in which a violation of requirements has been notified.

NEXT 3-A PUBLICATION REPORT DATE: November 2014



## **C.S.F. INOX SPA**

### **PREFACE AND WARNING**

This publication does not constitute a contract proposal or an offer to the public or product advertisement.

This publication is reserved to the internal operators of C.S.F. INOX.

Any kind of product sale and marketing can occur only according to the general terms of contract and special conditions listed by C.S.F. INOX as per contract forms.

All the instructions, data and representations (in whatever way executed) listed in this publication are indicative and do not binding.

C.S.F. does not stand surety or undertake any obligation for the utilisation of this document and for the information contained. In particular, it does not guarantee against omissions or errors of the data and drawings here indicated.

Notice that the technical specifications, information and representations in this document are merely indicative and approximate.

C.S.F. INOX reserves the right at any moment and without notice to modify the data, drawings and information indicated in this document.

C.S.F. INOX recommends anyone to verify with the C.S.F. INOX operators contractual conditions and the product characteristics as per the official documents attached to all products in the C.S.F. INOX range.

All the general and non-binding technical specifications and representations may not correspond to the real conditions of the products and to their operating modes for each different application.

C.S.F. INOX guarantees its own products according to the general guarantee conditions in compliance with the required modes of utilisations as per separate documents, regardless of what is indicated in this document, if the assembly and operating methods of the products are observed.

Only the instructions indicated in the contract documents, if duly undersigned by authorised C.S.F. INOX personnel, are binding for C.S.F. INOX.

We remind our technical and business collaborators to show the customer our range of products indicating the technical specifications of each type, with the conditions of utilisation and the actual utilisation methods.

Please consider this warning carefully because C.S.F. INOX shall not be liable for any utilisation of this document, of the data and representations here indicated.

# Hygienic Centrifugal pumps

## CSA Series

CSA series pumps are designed, tested and approved to EHEDG (European Hygienic Engineering & Design Group) hygiene protocols and to US 3A standards. Used mainly in the foodstuffs and pharmaceutical industries, they fulfil the highest sanitary requirements.

The modular construction enables CSF to provide the most suitable pump. Optimised performance and low NPSH requirements are integral to the design of CSA Series pumps.

Standard design

Open impeller.

Wetted parts in CF-3M 1.4404 / AISI 316L stainless steel, investment cast and electro-chemically polished.

Special internal finish to 0,5 micron Ra.

Adjustable stainless steel feet.

Flow rates up to 300 m<sup>3</sup>/h, heads up to 100 m (10 bar); low NPSH requirements.



# Sanitary Self-Priming Pumps

## ASH series

ASH Series pumps are approved to the latest US 3A sanitary standards; ideal for systems where compliance to the most strict hygiene regulations is essential.

The ability of ASH pumps to repeatedly create a vacuum makes them ideal for applications where air or gas is entrained in the pumped liquid. Perfect for CIP scavenge and duties where the inlet pipework is only partially filled with fluid, including foaming products.

Manufactured for a wide range of requirements in the food, beverage and pharmaceutical process sector. This market leading design includes the latest technologies and construction materials.

Standard design

Wetted parts in CF-3M 1.4404 / AISI 316L stainless steel.

Investment cast and electro-chemically polished.

Special internal finish 0,8 micron Ra.

Adjustable stainless steel feet.

Flow rates up to 40 m<sup>3</sup>/h, heads up max. 35 m (3,5 bar) (50 Hz).



# SANITARY CENTRIFUGAL PUMPS SERIES CSA



## INDEPENDENT SUPPORT

Sturdy and modular support to be integrated in the various solutions.



## SEPARATE MOTOR

For a self-sufficient choice in compliance with the following standards:

- IEC 34 - 1
- VDE 0530T1
- NF C51 - 111
- BS 5000 PART. 99
- NEMA MG1 PART. 1



## CASING COVER

Achieved from solid, machined and polished according to hygienical regulations with roughness of 0,5 micron.



## IMPELLER

With incorporated bush for a better rigidity and cleaning.

Manufactured with perfect shapes, thickness and materials and balanced thanks to the investment casting procedure.

Manual and electrochemical polishing for specular surfaces and low roughness values.



## CASING

Volute casing with circular cross section. Perfect development of the shapes ensured by the investment casting procedure. Internal finishing suitable with cover and impeller.

# CSA SERIES

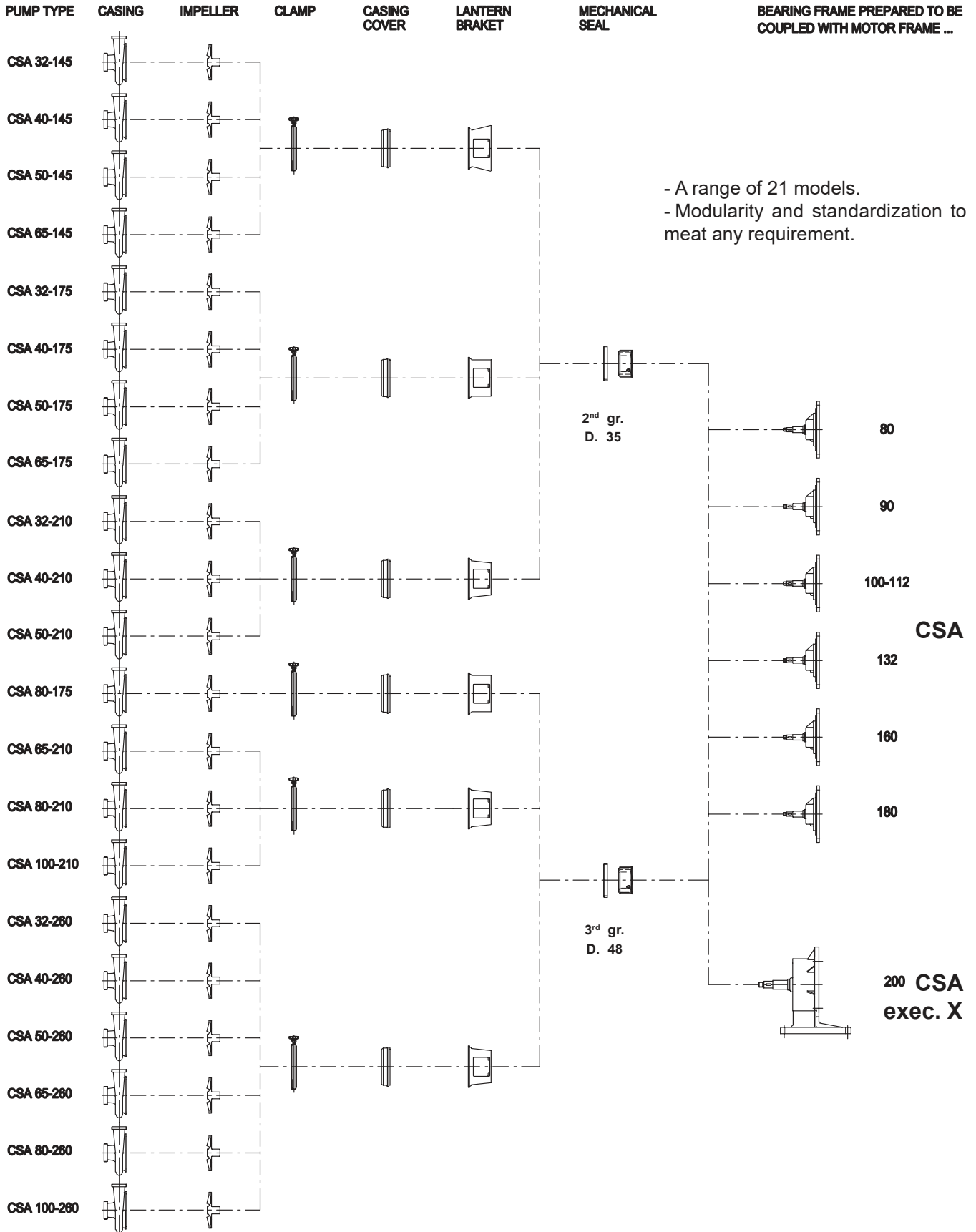

# PUMP CODES GUIDE

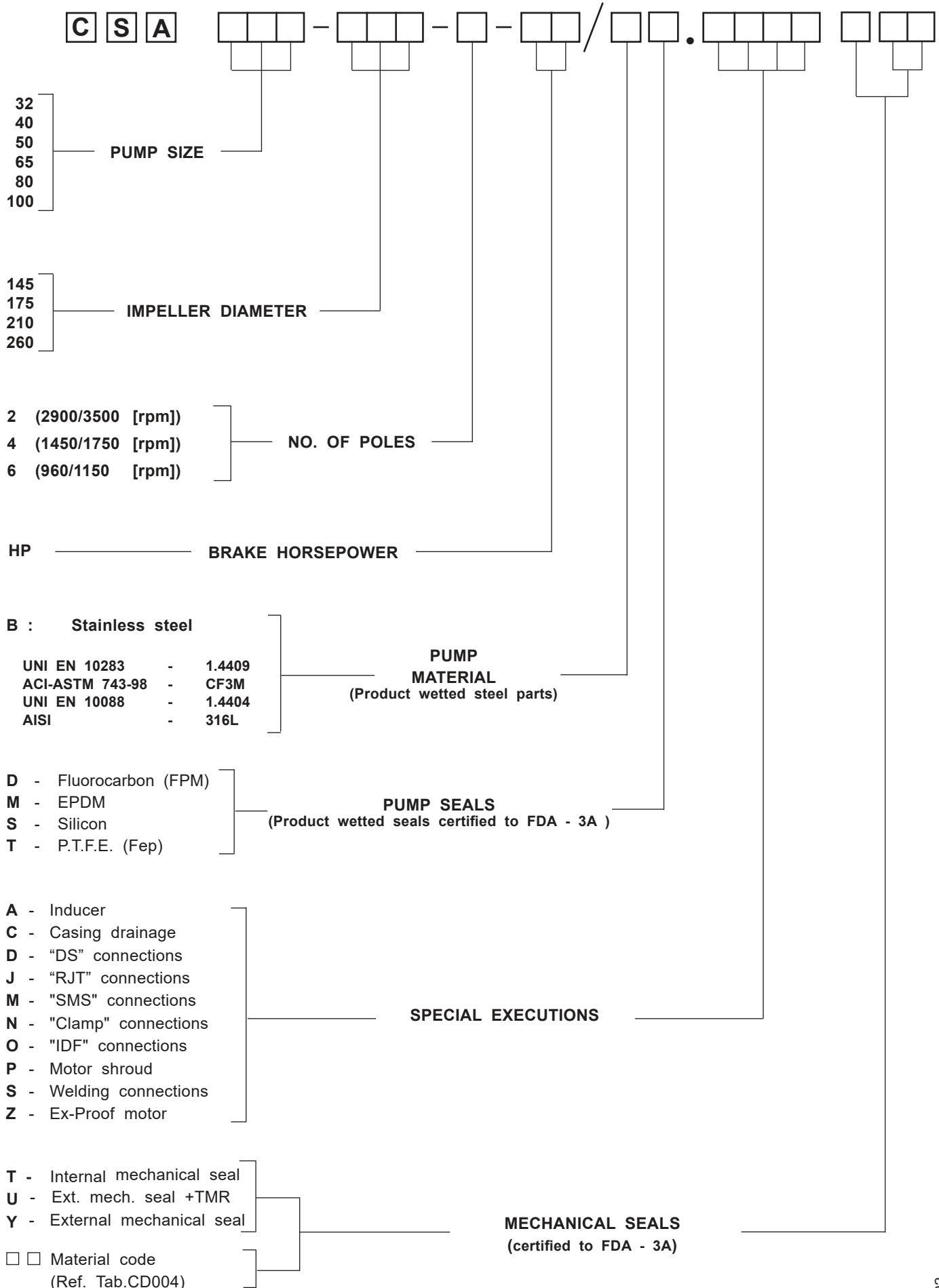

Example: **CSA 50-210-2-20/BM.NY71**

# GENERAL DIAGRAM CSA

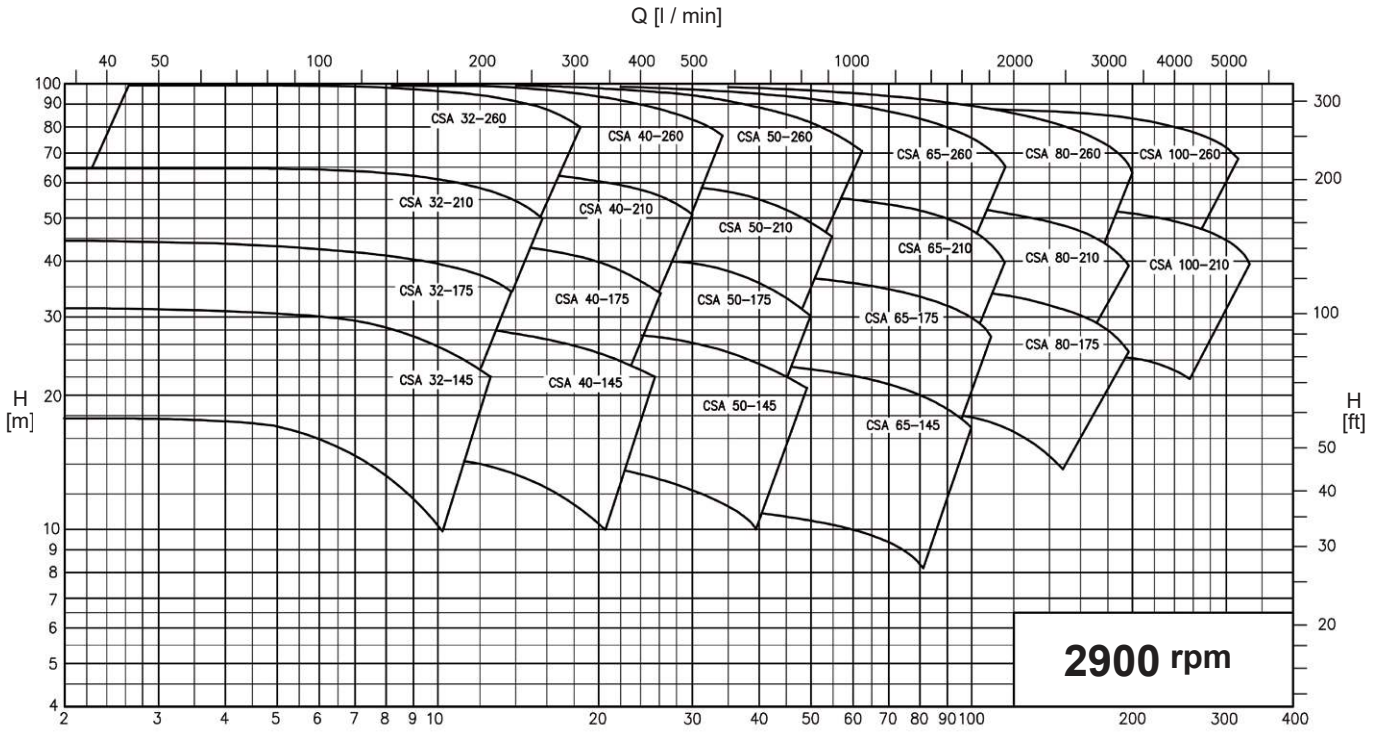

Performance applies to H<sub>2</sub>O at 20 °C (68 °F), 1013 millibar

Q [m<sup>3</sup> / h]

Data not binding.

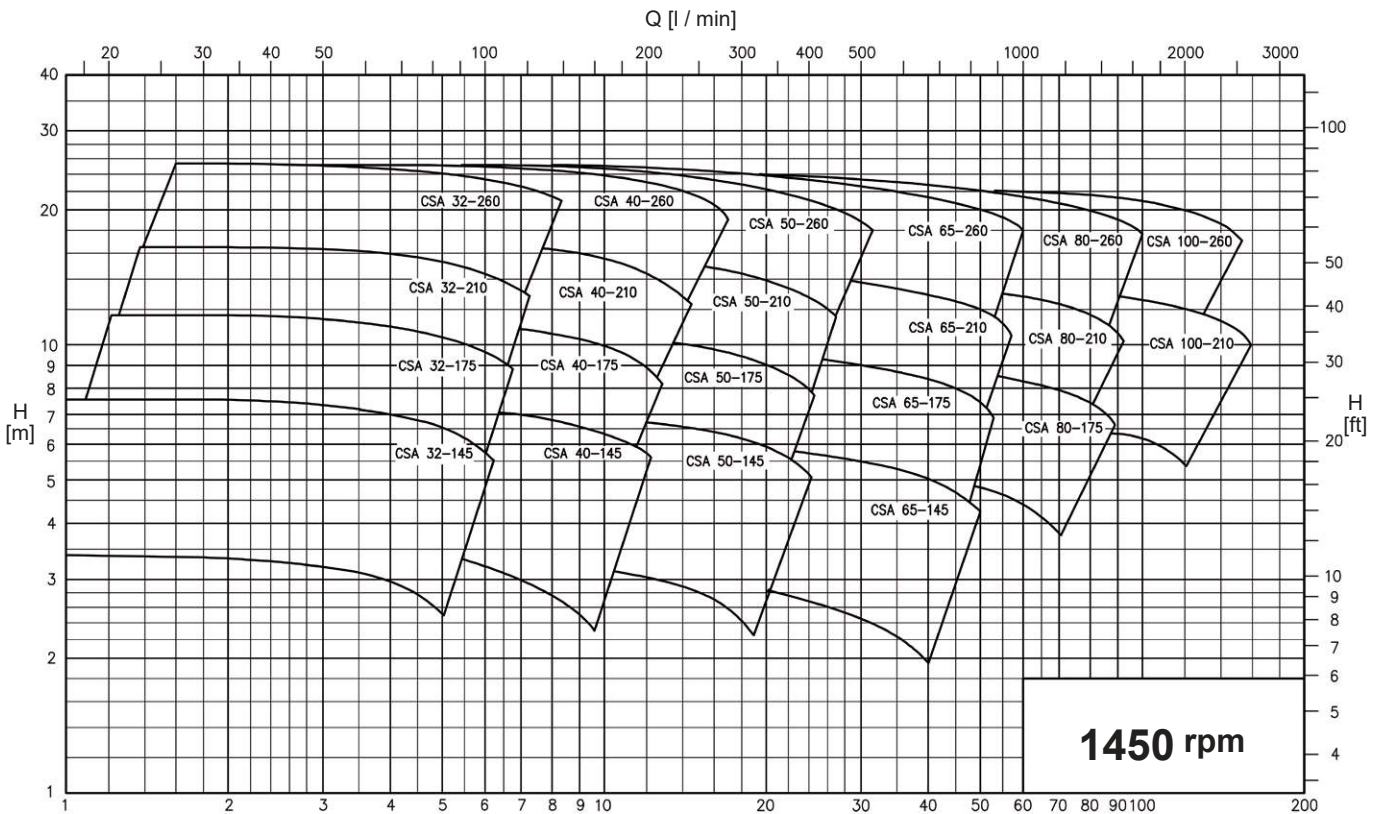

Performance applies to H<sub>2</sub>O at 20 °C (68 °F), 1013 millibar

Q [m<sup>3</sup> / h]

Data not binding.

**AS REGARDS PERFORMANCE CURVES SEE CS CATALOGUE**

Closed coupled sanitary centrifugal pumps with open impeller and independent shaft support.  
 Greased lubricated bearings.  
 Clamp design casing and seal. Easy disassembly, quick inspection, cleaning and maintenance. Rotation of the delivery port for optimised installation.



**Elastomers (certified to FDA - 3A - USP VI):**

- EPDM
- FLUOROCARBON - (FPM)
- P.T.F.E. (FEP)

**Connections:**

- CLAMP DIN 32676-C
- DIN 11864



# MECHANICAL SEALS

CSA pumps has mechanical seal designed according to the 3A and EHEDG standards.

The seal components are available in a wide range of materials to be selected according the product to pump, the temperature and the working performance.

**MATERIAL CODES**

**METALS**

- X - Stainless steel  
AISI 316L
- L - Hastelloy (Ni alloy)

**CARBONS**

- V - normal carbon
- Z - special carbon

**RESINS**

- 5 - normal PTFE
- 4 - loaded PTFE
- F - O-Ring FEP

**METAL CARBONS**

- 3 - Hard metal welded on stainless steel (TUC)
- R - Anti-corrosion hard metal (TUC)
- K - Integral silicate carbon (SIC)

**ELASTOMERS**

- 6 - Nitrile (NBR)
- 7 - Ethylene propylene (EPDM)
- W - FPM for high T
- Y - Fluorocarbon (FPM)
- B - Silicone
- Q - Chemraz
- U - Kalrez

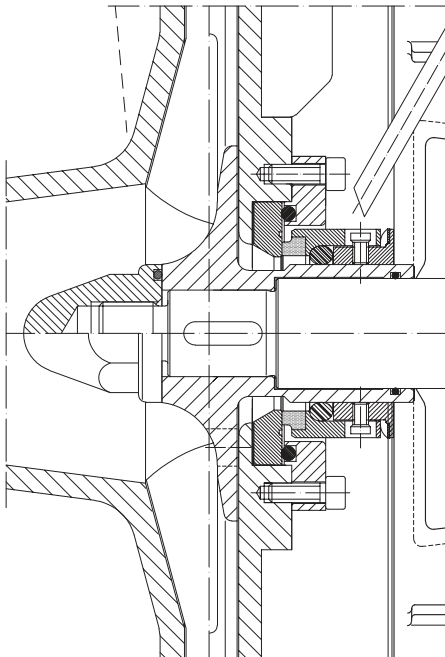

## EXECUTION Y

**EXTERNAL MECHANICAL SEAL "Y"**

Special external mechanical seal execution specifically designed for autolubrication and optimization of cleaning and sterilization.

External flushing for cooling





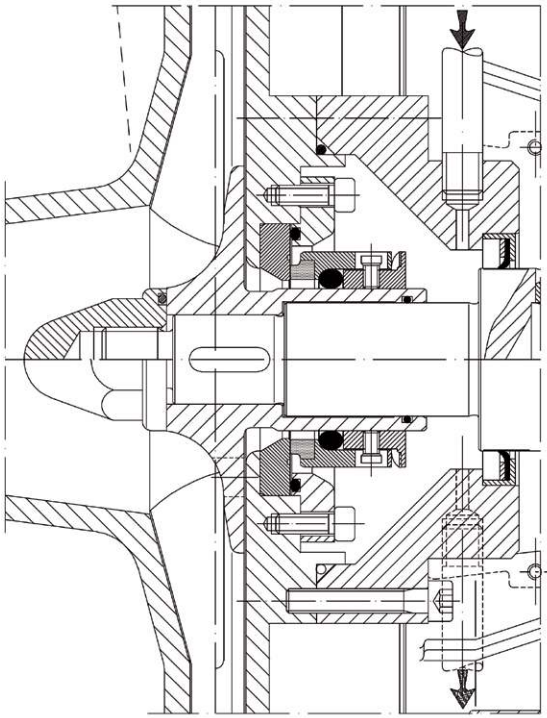

## EXEC. U

### EXTERNAL MECHANICAL SEAL + TMR FLUSHED

Double mechanical seal with circulation of the cleaning and cooling liquid.

It is used with products that tend to crystallise, to glue, to harden, to be abrasive, to reach high temperatures and whenever the seal life is limited.

The function of the fluxing is to clean, lubricate and cool the seal; the circulating liquid must be clean.

If the seal is leaking the fluxing liquid will point out this fault.



### INTERNAL MECHANICAL SEAL

## EXECUTION H

It contemplates the assembly of a mechanical seal dipped in the product, placed behind the impeller in a conic chamber with appropriate lubrication conditions.

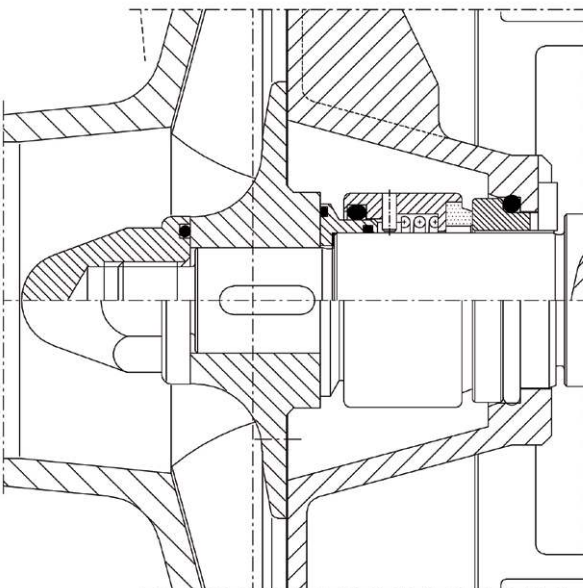

Protected and balanced execution. It is suitable for viscous and dirty products, for vacuum applications or those subject to differences in pressure. It is easily cleaned and therefore ideal for sanitary and pharmaceutical applications etc.



# CSA OVERALL DIMENSIONS

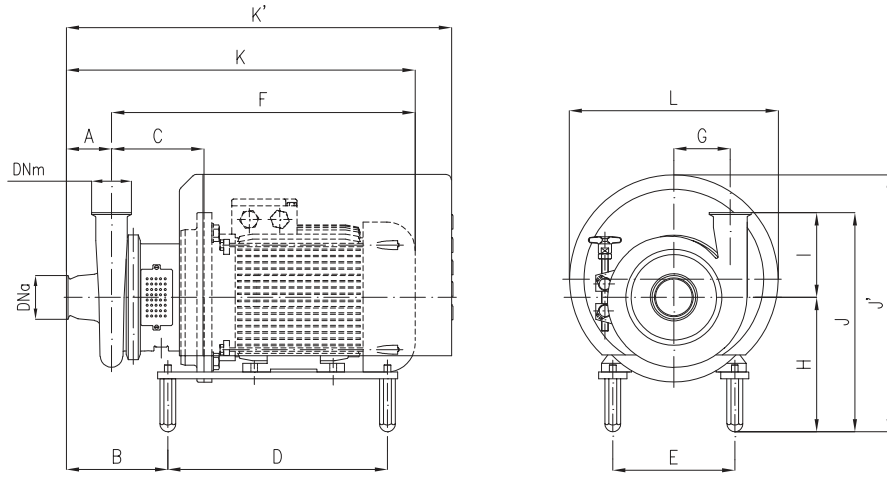

Dimensions not binding - DN = "Clamp" DIN 32676-C connections, with standard IEC/EN motors

Pumps	IEC motors size:	DNa	DNm	A	B	C	D	E	F	G	H	K	K'	I	J	J'	L				
CSA 32-145	80	1 1/2"	1 1/2"	80	166	138	254	125	372	85	220	452	566	148	368	384	298				
	90				172			140	419		230	499			378	394					
	100				158	139	314	160	451		240	531	637		388	445	330				
	112							165	190		473	230			553	378		435			
CSA 32-175	80	1 1/2"	1 1/2"	80	167	139	254	125	373	95	220	453	567	148	368	384	298				
	90				173			140	420		230	500			378	394					
	100				159	140	314	160	452		240	532	637		388	445	330				
	112							166	190		473	230			553	378		435			
CSA 32-210	80	1 1/2"	1 1/2"	80	167	139	254	125	373	110	230	453	567	168	398	402	298				
	90				173			140	420		240	532			398	435					
	100				159	140	314	160	452		230	553	637		408	445	330				
	112							166	190		473	230			553	398		435			
	132 M-S				177	161	389	216	578		255	614	680		423	477	370				
	132 MB							241	206		460	254	684		280	764	935	448	543	430	
160																					
CSA 32-260	90	2"	1 1/2"	90	207	163	254	140	444	140	260	534	601	168	428	465	330				
	100				193			160	476			566	671					424	298		
	112				164	314	190	497	587			671	465					330			
	132 M-S						211	185	389			216							558	602	482
	132 MB				270	225	460	254	703			648	714					448	543	430	
	160											693	769								
CSA 40-145	80	2"	2"	80	167	139	254	125	373	90	220	453	567	133	353	384	298				
	90				173			140	420						230	501		363	394		
	100				159	140	314	160	452				240		532	637	373	445	330		
	112							166	190				473		230		553	363		435	
CSA 40-175	80	2"	2"	80	168	141	254	125	375	95	220	455	569	150	370	384	298				
	90				175			140	422						230	502		380	394		
	100				161	142	314	160	454				240		534	639	390	445	330		
	112							168	190				475		230		555	380		435	
	132 M-S				180	164	389	216	537				255		617	682	405	477	370		
	132 MB							243	208				460		254	686	280	766	937	430	543
160																					
CSA 40-210	80	2"	2"	80	168	141	254	125	375	115	235	455	569	160	395	399	298				
	90				175			140	422						240	534		395	445		
	100				161	142	314	160	454				235		555	639	400	445	330		
	112							168	190				475		235		555	395		440	
	132 M-S				180	164	389	216	537				250		617	682	410	472	370		
	132 MB							243	208				460		254	686	280	766	937	440	543
160																					
CSA 40-260	90	2"	2"	100	217	163	254	140	444	145	260	544	611	172	432	465	330				
	100				203			160	476									576	681	440	298
	112				164	314	190	497	597				681					465	330		
	132 M-S						221	185	389				216							558	724
	132 MB				280	225	460	254	703				702					779	452	502	430
	160																				
CSA 50-145	80	2 1/2"	2"	80	169	141	254	125	374	95	220	454	569	139	359	384	298				
	90				175			140	422						230	502		369	394		
	100				161	142	314	160	454				240		534	639	379	445	330		
	112							168	190				475		230		555	369		435	
	132 M-S				180	164	389	216	537				255		617	682	394	477	370		
	160																				
CSA 50-175	80	2 1/2"	2"	80	169	141	254	125	374	100	230	454	569	154	384	394	298				
	90				175			140	422						240	534		394	445		
	100				161	142	314	160	454				230		555	639	384	435	330		
	112							168	190				475		230		555	384		435	
	132 M-S				180	164	389	216	537				255		616	682	409	477	370		
	132 MB							243	208				460		254	686	280	766	937	434	543
160																					

# CSA OVERALL DIMENSIONS

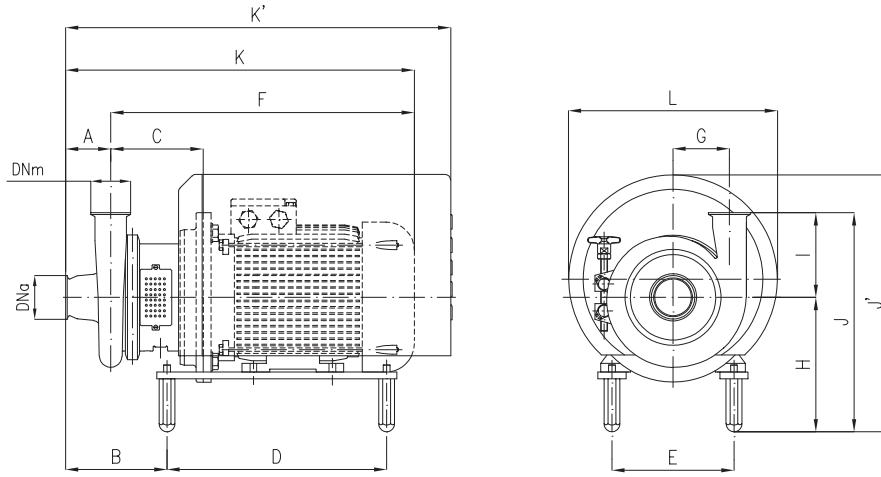

Dimensions not binding - DN = "Clamp" DIN 32676-C connections, with standard IEC/EN motors

Pumps	IEC motors size:	DNa	DNm	A	B	C	D	E	F	G	H	K	K'	I	J	J'	L								
CSA 50-210	90	2 1/2"	2"	80	175	141	254	140	422	120	240	502	569	168	408	412	298								
	100				161	142	314	160	454			534	639			445	330								
	112				168			190	475			555													
	132 M-S				180	164	389	216	537			617	682			418	472	370							
	132 MB				243	208	460	254	686			280	766			937	448	543	430						
	160				173	223	600	279	783			305	863			1072	473	637	420						
CSA 50-260	100	2 1/2"	2"	90	194	165	314	160	477	145	270	567	672	179	449	475	330								
	112				201			190	498			588													
	160				273	228	460	254	706			280	796					970	459	543	430				
	180				188	600	279	788	305			878	1087					484	637	420					
CSA 65-145	80	3"	3"	79	172	145	254	125	379	112	245	458	572	138	383	409	298								
	90				178			140	426			505	642					393	450	330					
	100				164	146	314	160	458			537													
	112				171			190	479			558													
	132 M-S				183	168	389	216	541			620	685								393	477	370		
	132 MB				246	212	460	254	690			280	769								940	418	543	430	
160	178	144	254	140	425	305	864	1073	443	637	420														
CSA 65-175	90	3"	3"	80	164	145	314	160	457	120	255	537	642	138	393	460	330								
	100				171			190	478			558													
	112				183	167	389	216	540			620	685					418	543	430					
	132 M-S				246	211	460	254	689			280	769								940				
	132 MB				174	224	600	279	784			305	864								1073	443	637	420	
	160				212	168	254	140	449			539	605								158	423	470	330	
180	198	169	314	160	481	571	676																		
CSA 65-210	90	3"	3"	90	205			190	502	135	265	592		158	438	543	430								
	100				276	231	460	254	709			280	799					974							
	112				191	600	279	791	305			881	1090					463	637	420					
	160				207	168	314	160	480			580	685					193	478	507					370
112	214			190	501	601																			
132 M-S	226	190	389	216	563	663	728	193	478	507	370														
132 MB	226	190	389	216	607	707	783																		
160	285	230	460	254	708	808	983					498	637	420											
180	200	600	279	790	305	890	1099																		
CSA 80-175	100	4"	3"	100	231	174	315								160	486	139	275	586	691	164	439	480	330	
	112				220										190	507			607						
	132 M-S				231	195	389	216	568	668	734				164	444			543	430					
	160				291	236	460	254	714	280	814														989
180	206	600	279	796	305	896	1105	469	637	420															
CSA 80-210	100	4"	3"	100	210	171	314	160	483	145	285	583	688	164			449	490			330				
	112				217			190	504			604													
	132 M-S				229	193	389	216	566			666	731		164	449			507	370					
	160				288	233	460	254	711			811	986												
	180				203	600	279	793	305			893	1102									469	637	420	
	100				210	171	314	160	483			583	688												209
112	217			190	504	604																			
132 M-S	229	193	389	216	566	666	731	209	509	522	370														
132 MB	229	193	389	216	610	710	786																		
160	288	233	460	254	711	811	986					214	519	527	370										
180	246	200	389	216	573	683	750																		
CSA 100-210	132 M-S	5"	4"	111	221	240	600									279	800	161	305	911	1120	214	519	634	420
	180				246	195	389									216	612			727	803				
CSA 100-260	132 MB	5"	4"	115	305	235	460	254	713	186	325					828	1004	216	541	588	430				
	160				220			600	279							795	910					1118			
	180																								

# SANITARY SELF-PRIMING PUMPS ASH SERIES



## INDEPENDENT SUPPORT

In stainless steel for different sizes, suitable for motors IEC - NEMA.



## SEPARATE MOTOR

For a self-sufficient choice in compliance with the following standards:

- IEC 34 - 1
- VDE 0530T1
- NF C51 - 111
- BS 5000 PART. 99
- NEMA MG1 PART. 1



## CASING

Casing with side duct, of suitable thickness and perfect development of the shape enhanced by investment casting. Internal finishing by polishing with roughness of 0,8 micron.



## IMPELLER

Manufactured from solid with perfect shapes, thickness and materials. Roughness of 0,8 micron obtained by electro-chemical polishing.



## COVER

Achieved by investment casting, machined and polished according to hygienical regulations with roughness of 0,8 micron.

# PUMP CODES GUIDE

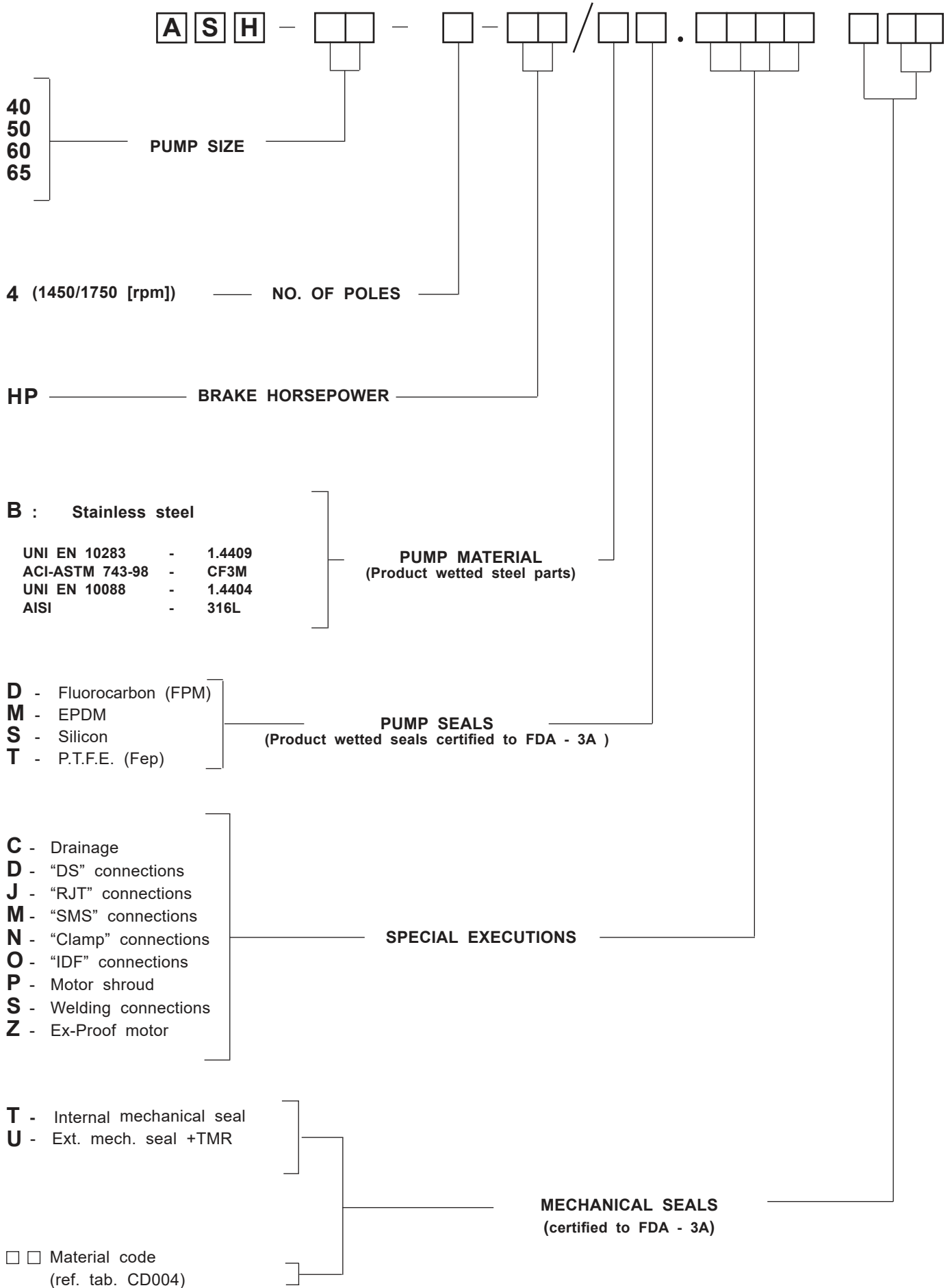

Example: **ASH 50-4-3/BM.P**

# GENERAL DIAGRAM ASH

## A 50 Hz

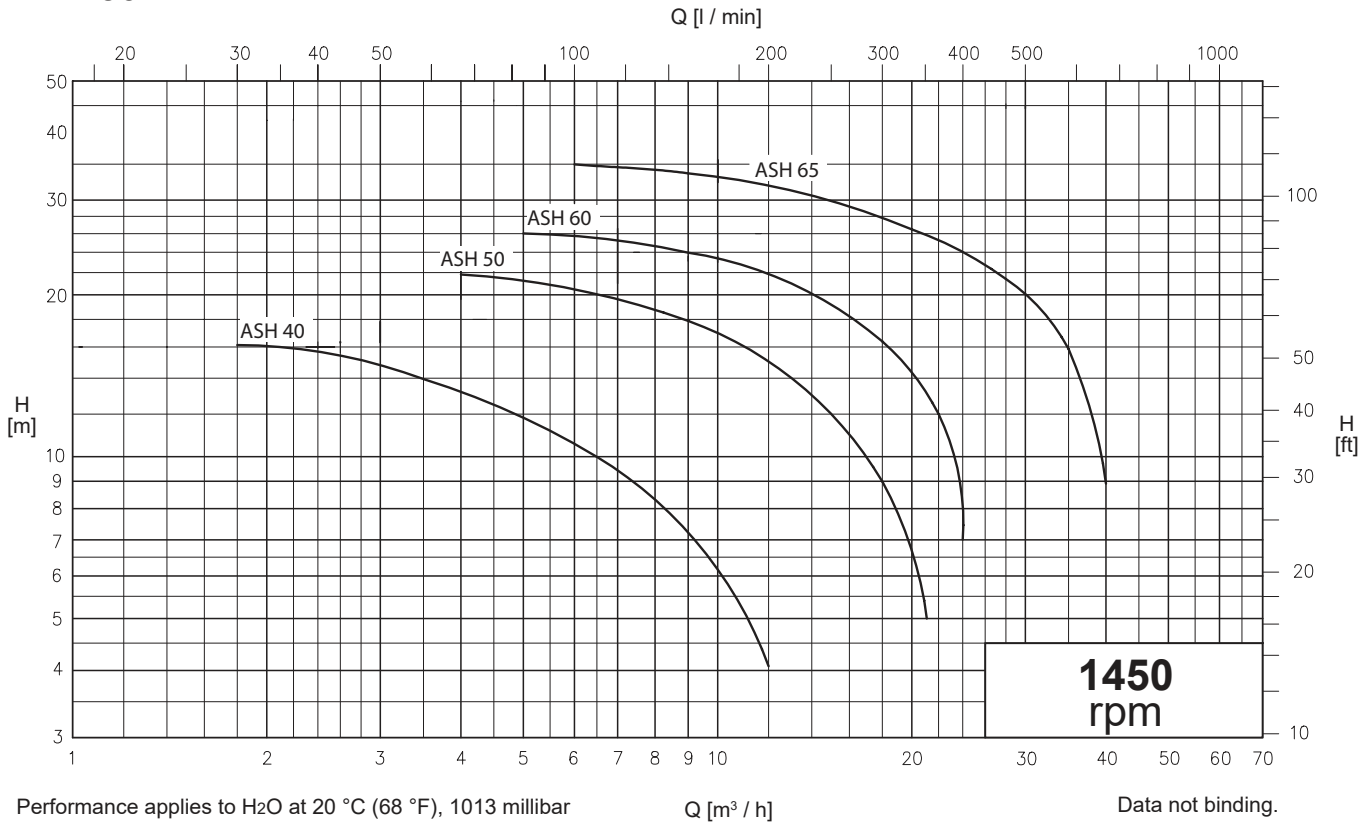

## A 60 Hz

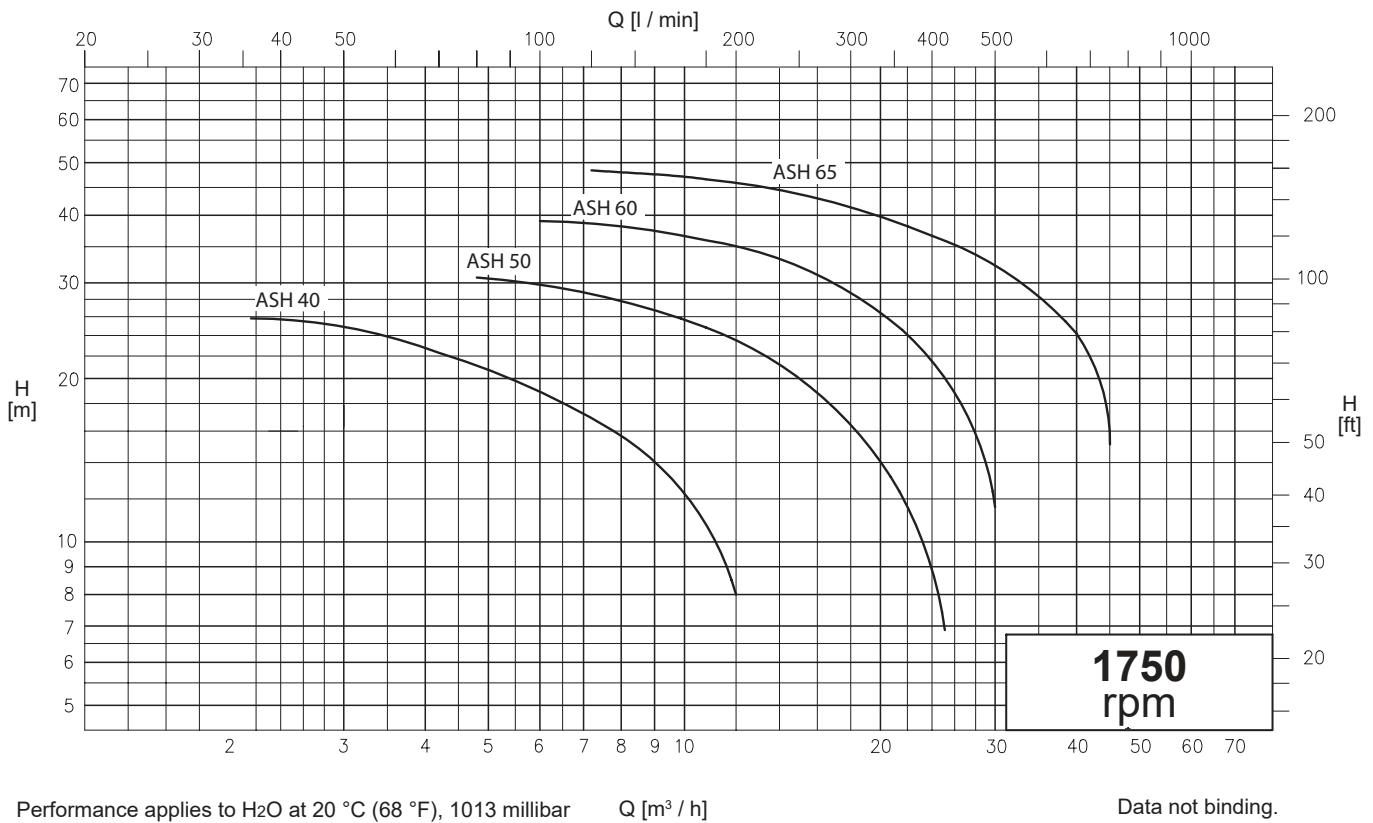

# ASH series

Close coupled sanitary self-priming pumps with independent shaft support.

Suitable for motors in compliance with the following standards: IEC 34-1

VDE 0530T1

NF C51-111

BS5000 PART 99

NEMA NG1 PART. 1



n° 02 - 11 739

Greased lubricated bearings.

Clamp design casing and seal. Easy disassembly, quick inspection, cleaning and maintenance.

## Seals:

Single internal mechanical seal, protected, balanced and bi-directional, with seats according to EN 12756, ISO 3069.

**Elastomers** (certified to FDA - 3A - USP VI):

EPDM

FLUOROCARBON - (FPM)

P.T.F.E. (FEP)

## Connections:

CLAMP DIN 32676-C

DIN 11864



# MECHANICAL SEALS

## MATERIAL CODES

### METALS

X - Stainless steel

AISI 316L

L - Hastelloy (Ni alloy)

### CARBONS

V - normal carbon

Z - special carbon

### RESINS

5 - normal PTFE

4 - loaded PTFE

F - O-Ring FEP

### METAL CARBONS

3 - Hard metal welded on stainless steel (TUC)

R - Anti-corrosion hard metal (TUC)

K - Integral silicate carbon (SIC)

### ELASTOMERS

6 - Nitrile (NBR)

7 - Ethylene propylene (EPDM)

W - FPM for high T

Y - Fluorocarbon (FPM)

B - Silicone

Q - Chemraz

U - Kalrez

## INTERNAL MECHANICAL SEAL

### EXECUTION H

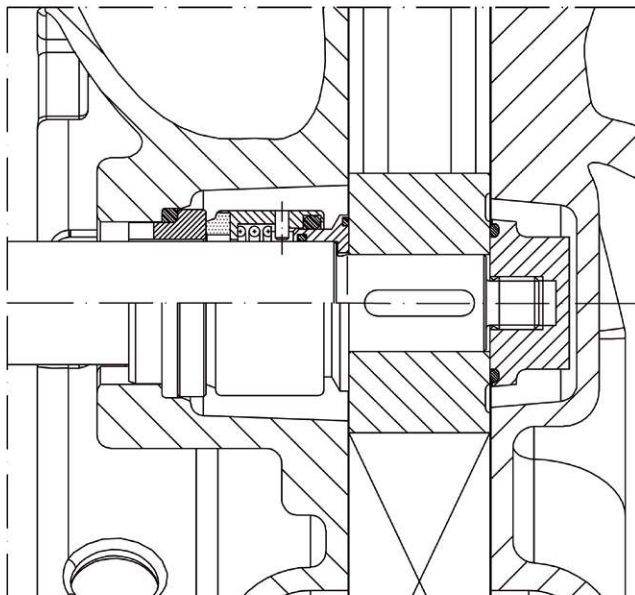

It contemplates the assembly of a mechanical seal dipped in the product, placed behind the impeller in a conic chamber with appropriate lubrication conditions. Protected and balanced execution with a shape easily cleanable ideal for sanitary and pharmaceutical applications. It is suitable for viscous and dirty products, vacuum applications or those subject to differences in pressure.



# ASH OVERALL DIMENSIONS

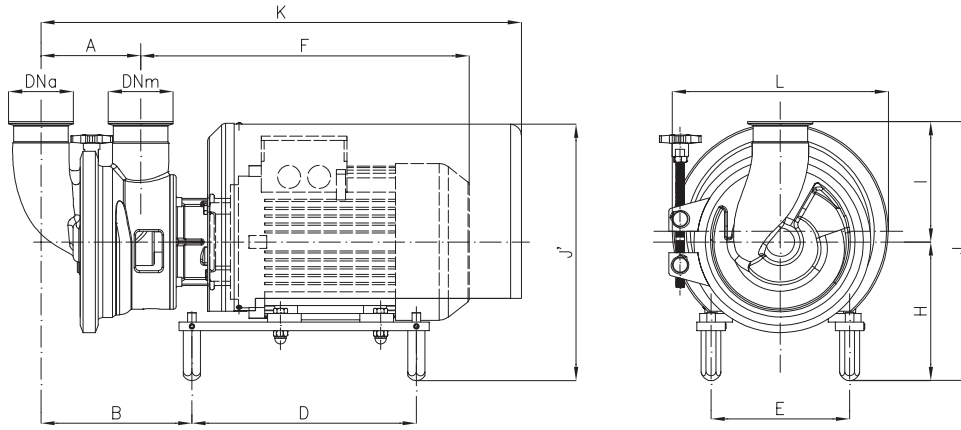

Dimensions not binding - DN = "Clamp" DIN 32676-C connections, with standard IEC/EN motors

Pumps	1450 rpm	kW	DNa	DNm	A	B	D	E	F	H	K	I	J	J'	L							
ASH 40		1,1	1" 1/2	1" 1/2	90,5	183	245	140	410	228	551	139	376	376	239							
	1,5	148,5				314										160	433	238	617	386,5	403	330
	2,2	176,5				314										160	432	238	645	386,5	403	330
ASH 50	2,2	2"	2"	118	183,5	314	190	453	250	645	149	398,5	415	330								
	4				211										314	190	460	250	672	418,5	415	330
	5,5				215										390	216	512	270	749	438,5	489	372
ASH 60	4	3"	3"	139	211	314	190	460	250	672	169	418,5	415	330								
	5,5				215										390	216	512	270	749	438,5	489	372
	7,5				215										390	216	512	270	749	438,5	489	372
ASH 65	5,5	3"	3"	139	215	390	216	512	270	749	169	438,5	489	372								
	7,5				266										460	254	650	280	914	448,5	536	432
	15				266										460	254	650	280	914	448,5	536	432



# CURVE CARATTERISTICHE

## PERFORMANCE CURVES

# Serie ASH

## ASH Series

1450 giri/min - 1450 rpm

POMPA TIPO Pump type		<b>ASH 40</b>		<b>n 1400</b>	<b>giri / min</b> r. p. m.
GIRANTE - Impeller					
TIPO Type	N° di pale n° of vanes	Pass. sferico max. sphere	φ max max. diameter	φ min min. diameter	Bocche tipo Ports type
RADIALE	24	-- mm	145,5 mm	-- mm	CLAMP
			Bocca aspir. Discharge port	DN 1"1/2	
			Bocca mand. Suction port	DN 1"1/2	
CARATTERISTICHE DI FUNZIONAMENTO CON ACQUA PULITA A 20°C - PESO SPECIFICO 1 (kg/dm <sup>3</sup> ) Curves show performance with clear water at 70°F - Specific gravity 1 (kg/dm <sup>3</sup> )					

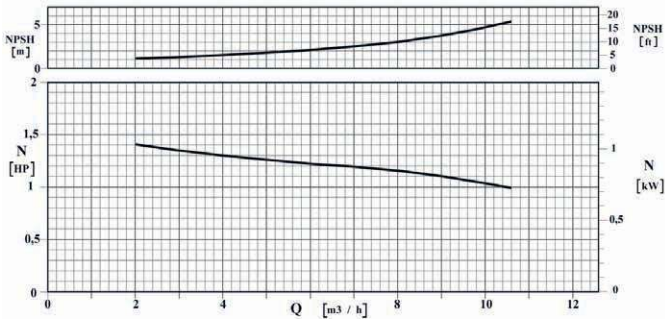
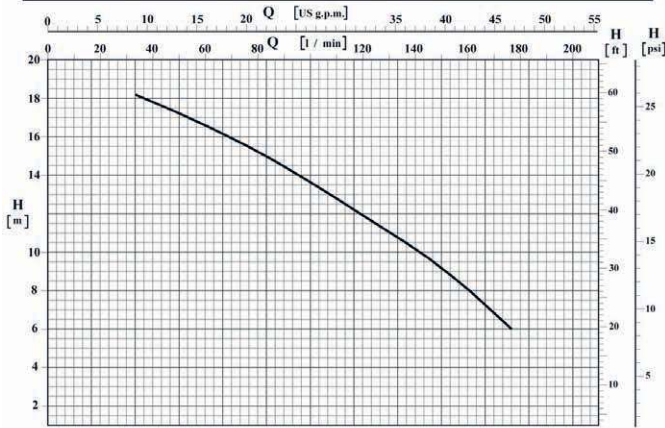

POMPA TIPO Pump type		<b>ASH 50</b>		<b>n 1450</b>	<b>giri / min</b> r. p. m.
GIRANTE - Impeller					
TIPO Type	N° di pale n° of vanes	Pass. sferico max. sphere	φ max max. diameter	φ min min. diameter	Bocche tipo Ports type
RADIALE	16	-- mm	164 mm	-- mm	CLAMP
			Bocca aspir. Discharge port	DN 2"	
			Bocca mand. Suction port	DN 2"	
CARATTERISTICHE DI FUNZIONAMENTO CON ACQUA PULITA A 20°C - PESO SPECIFICO 1 (kg/dm <sup>3</sup> ) Curves show performance with clear water at 70°F - Specific gravity 1 (kg/dm <sup>3</sup> )					

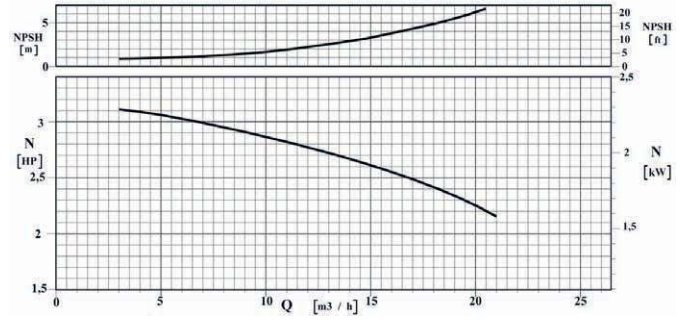
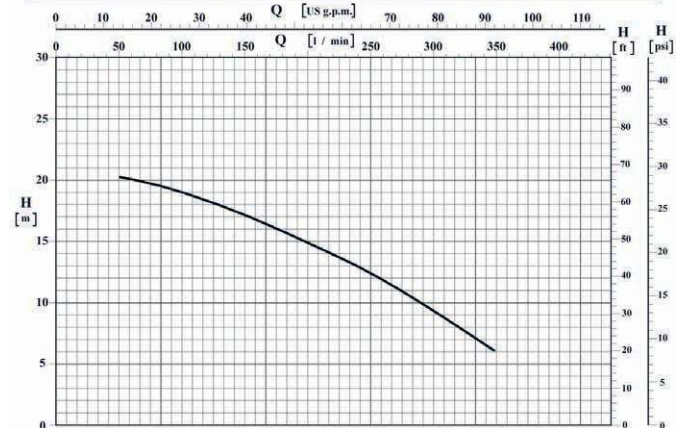

POMPA TIPO Pump type		<b>ASH 60</b>		<b>n 1450</b>	<b>giri / min</b> r. p. m.
GIRANTE - Impeller					
TIPO Type	N° di pale n° of vanes	Pass. sferico max. sphere	φ max max. diameter	φ min min. diameter	Bocche tipo Ports type
RADIALE	16	-- mm	200 mm	-- mm	CLAMP
			Bocca aspir. Discharge port	DN 3"	
			Bocca mand. Suction port	DN 3"	
CARATTERISTICHE DI FUNZIONAMENTO CON ACQUA PULITA A 20°C - PESO SPECIFICO 1 (kg/dm <sup>3</sup> ) Curves show performance with clear water at 70°F - Specific gravity 1 (kg/dm <sup>3</sup> )					

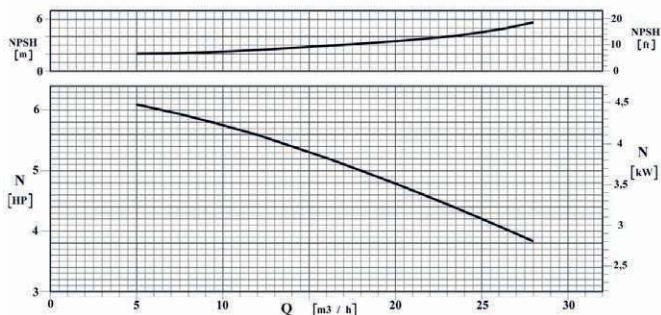
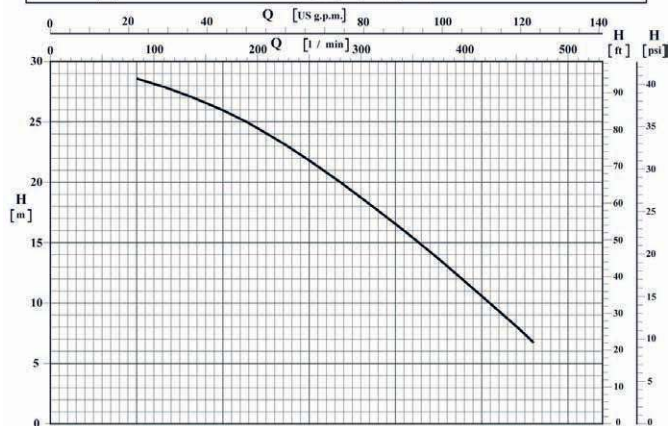

POMPA TIPO Pump type		<b>ASH 65</b>		<b>n 1450</b>	<b>giri / min</b> r. p. m.
GIRANTE - Impeller					
TIPO Type	N° di pale n° of vanes	Pass. sferico max. sphere	φ max max. diameter	φ min min. diameter	Bocche tipo Ports type
RADIALE	16	-- mm	200 mm	-- mm	CLAMP
			Bocca aspir. Discharge port	DN 3"	
			Bocca mand. Suction port	DN 3"	
CARATTERISTICHE DI FUNZIONAMENTO CON ACQUA PULITA A 20°C - PESO SPECIFICO 1 (kg/dm <sup>3</sup> ) Curves show performance with clear water at 70°F - Specific gravity 1 (kg/dm <sup>3</sup> )					

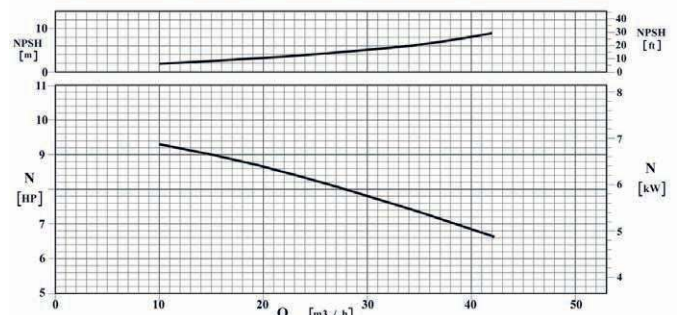
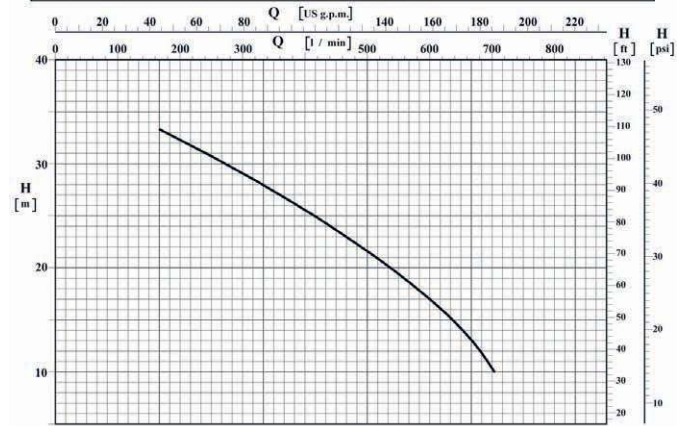

# CURVE CARATTERISTICHE

## PERFORMANCE CURVES

# Serie ASH

## ASH Series

1750 giri/min - 1750 rpm

POMPA TIPO Pump type		<b>ASH 50</b>			n	1750	giri / min r. p. m.
GIRANTE — Impeller							
TIPO Type	N° di pale n° of vanes	Pass. sferico max. sphere	φ max max. diameter	φ min min. diameter	Bocche tipo Ports type	Bocca aspir. Discharge port	DN 2"
RADIALE	16	-- mm	164 mm	-- mm	CLAMP	Bocca mand. Suction port	DN 2"
CARATTERISTICHE DI FUNZIONAMENTO CON ACQUA PULITA A 20°C - PESO SPECIFICO 1 (kg/dm <sup>3</sup> ) Curves show performance with clear water at 70°F - Specific gravity 1 (kg/dm <sup>3</sup> )							

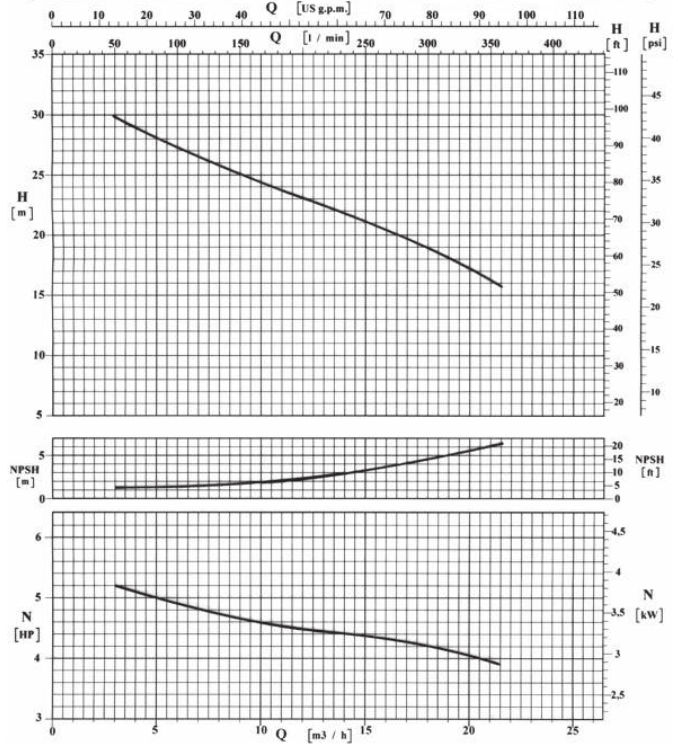

POMPA TIPO Pump type		<b>ASH 60</b>			n	1750	giri / min r. p. m.
GIRANTE — Impeller							
TIPO Type	N° di pale n° of vanes	Pass. sferico max. sphere	φ max max. diameter	φ min min. diameter	Bocche tipo Ports type	Bocca aspir. Discharge port	DN 3"
RADIALE	16	-- mm	200 mm	-- mm	CLAMP	Bocca mand. Suction port	DN 3"
CARATTERISTICHE DI FUNZIONAMENTO CON ACQUA PULITA A 20°C - PESO SPECIFICO 1 (kg/dm <sup>3</sup> ) Curves show performance with clear water at 70°F - Specific gravity 1 (kg/dm <sup>3</sup> )							

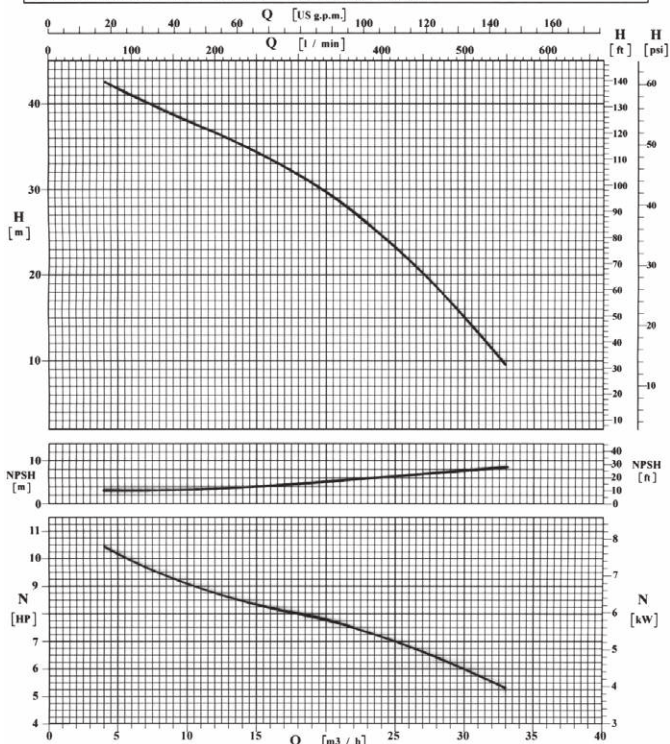

POMPA TIPO Pump type		<b>ASH 65</b>			n	1750	giri / min r. p. m.
GIRANTE — Impeller							
TIPO Type	N° di pale n° of vanes	Pass. sferico max. sphere	φ max max. diameter	φ min min. diameter	Bocche tipo Ports type	Bocca aspir. Discharge port	DN 3"
RADIALE	16	-- mm	200 mm	-- mm	Clamp	Bocca mand. Suction port	DN 3"
CARATTERISTICHE DI FUNZIONAMENTO CON ACQUA PULITA A 20°C - PESO SPECIFICO 1 (kg/dm <sup>3</sup> ) Curves show performance with clear water at 70°F - Specific gravity 1 (kg/dm <sup>3</sup> )							

